

Pinza pneumatica a 2 griffe ad azione parallela autocentrante (serie PE)

- Azionamento a doppio effetto (a semplice effetto su richiesta per PE-25... e PE-45...).
- Assenza di organi di trasmissione: elevato rendimento e affidabilità.
- Possibilità di scelta su un'ampia gamma di corse.
- Forza di serraggio costante su tutta la corsa in apertura ed in chiusura.
- Basso peso ottenuto con una costruzione interamente in lega leggera.

2-jaw parallel self-centering pneumatic gripper (series PE)

- Double acting (single acting upon request for PE-25... and PE-45...).
- High efficiency and reliability due to the lack of driving parts.
- Wide choice of stroke length options.
- The gripping force is constant on both directions along total stroke.
- Light weight; due to its alloy construction.



PE-4580



PE-4560



PE-4540



PE-4520



PE-45200

PE-25100



PE-25200



PE-2560



PE-2540



PE-2520



PE-16200



PE-16150



PE-1680



PE-1640



PE-1625



PE-1610

	PE-1610	PE-1625	PE-1640	PE-1680	PE-16150	PE-16200
Fluido Medium	Aria compressa filtrata, lubrificata / non lubrificata Filtered, lubricated / non lubricated compressed air					
Pressione di esercizio Operating pressure range	2÷8 bar					
Temperatura di esercizio Operating temperature range	5÷60 °C.					
Forza di serraggio per griffa a 6 bar Gripping force at 6 bar on each jaw	100 N					
Forza di serraggio totale a 6 bar Total gripping force at 6 bar	200 N					
Corsa Stroke (±0.25 mm)	2x5 mm	2x12.5 mm	2x20 mm	2x40 mm	2x75 mm	2x100 mm
Frequenza max funzionamento Maximum working frequency	3 Hz	2 Hz	2 Hz	2 Hz	1 Hz	1 Hz
Consumo d'aria per ciclo Cycle air consumption	7 cm ³	14 cm ³	21 cm ³	39 cm ³	71 cm ³	97 cm ³
Tempo di chiusura senza carico Closing time without load	0.02 s	0.05 s	0.1 s	0.2 s	0.4 s	0.5 s
Ripetibilità Repetition accuracy	0.03 mm	0.03 mm	0.03 mm	0.03 mm	0.03 mm	0.03 mm
Peso Weight	200 g	250 g	350 g	500 g	900 g	1200 g

Forza di serraggio

I grafici mostrano la forza per griffa espressa dalla pinza in funzione della pressione, del braccio Z e del disassamento del punto di presa X.

Gripping force

The graphs show the gripping force on each jaw, as a function of the operating pressure, the gripping tool length Z and the overhanging X.

La forza indicata in questi grafici è riferita alla singola griffa. La forza totale è il doppio.

The force shown in these graphs refers to one jaw. The total force is double.

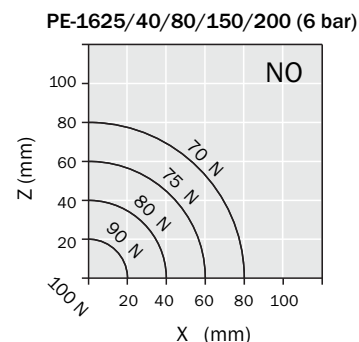
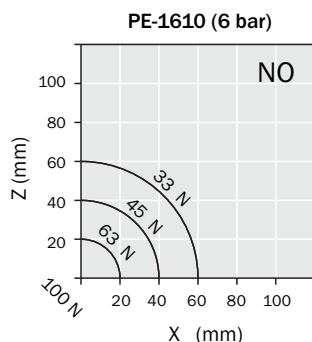
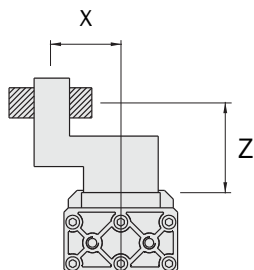
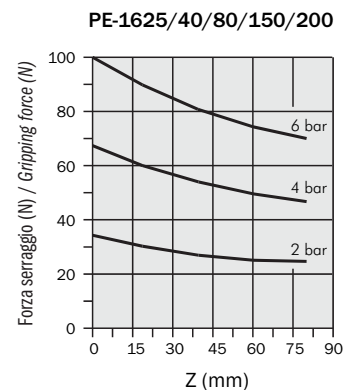
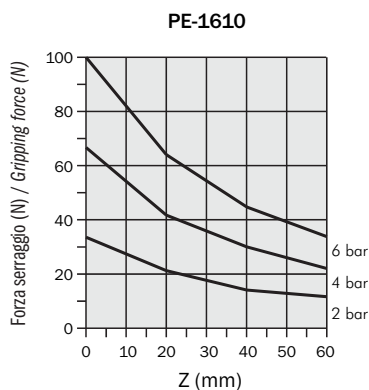
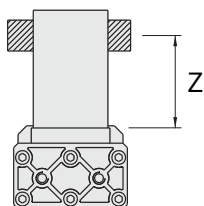

	PE-2520	PE-2540	PE-2560	PE-25100	PE-25200
Fluido Medium	Aria compressa filtrata, lubrificata / non lubrificata Filtered, lubricated / non lubricated compressed air				
Pressione di esercizio Operating pressure range	2÷8 bar				
Temperatura di esercizio Operating temperature range	5÷60 °C.				
Forza di serraggio per griffa a 6 bar Gripping force at 6 bar on each jaw	230 N				
Forza di serraggio totale a 6 bar Total gripping force at 6 bar	460 N				
Corsa (±0.25 mm) Stroke	2x10 mm	2x20 mm	2x30 mm	2x50 mm	2x100 mm
Frequenza max funzionamento Maximum working frequency	3 Hz	2 Hz	2 Hz	1 Hz	1 Hz
Consumo d'aria per ciclo Cycle air consumption	44 cm ³	74 cm ³	102 cm ³	146 cm ³	263 cm ³
Tempo di chiusura senza carico Closing time without load	0.02 s	0.04 s	0.06 s	0.08 s	0.17 s
Ripetibilità Repetition accuracy	0.04 mm	0.04 mm	0.04 mm	0.04 mm	0.04 mm
Peso Weight	700 g	980 g	1285 g	1235 g	2080 g

Forza di serraggio

I grafici mostrano la forza per griffa espressa dalla pinza in funzione della pressione, del braccio Z e del disassamento del punto di presa X.

Gripping force

The graphs show the gripping force on each jaw, as a function of the operating pressure, the gripping tool length Z and the overhanging X.

La forza indicata in questi grafici è riferita alla singola griffa. La forza totale è il doppio.

The force shown in these graphs refers to one jaw. The total force is double.

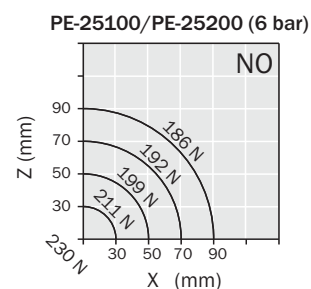
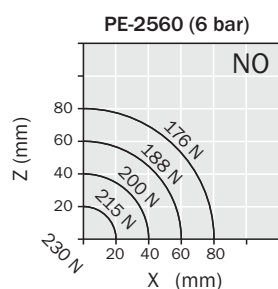
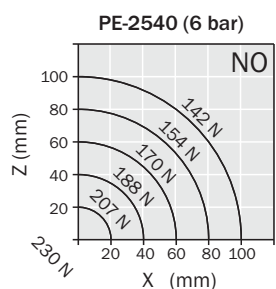
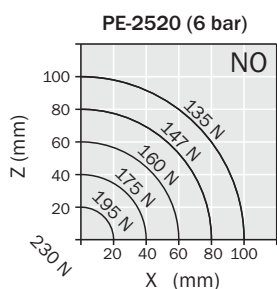
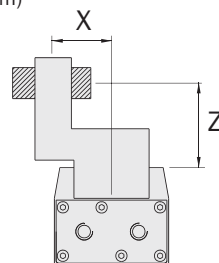
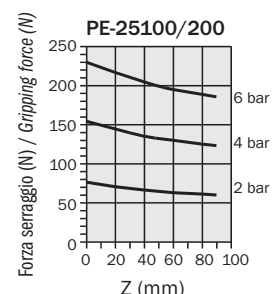
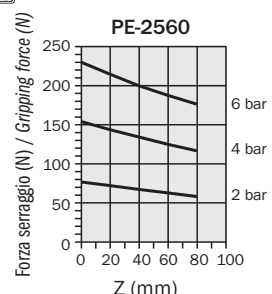
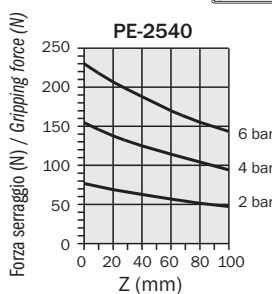
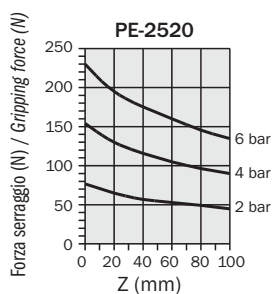
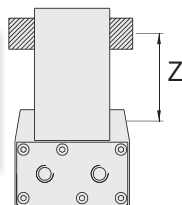

	PE-4520	PE-4540	PE-4560	PE-4580	PE-45200
Fluido Medium	Aria compressa filtrata, lubrificata / non lubrificata Filtered, lubricated / non lubricated compressed air				
Pressione di esercizio Operating pressure range	2÷8 bar				
Temperatura di esercizio Operating temperature range	5÷60 °C.				
Forza di serraggio per griffa a 6 bar Gripping force at 6 bar on each jaw	700 N	700 N	700 N	700 N	900 N
Forza di serraggio totale a 6 bar Total gripping force at 6 bar	1400 N	1400 N	1400 N	1400 N	1800 N
Corsa (±0.25 mm) Stroke	2x10 mm	2x20 mm	2x30 mm	2x40 mm	2x100 mm
Frequenza max funzionamento Maximum working frequency	3 Hz	2 Hz	1 Hz	1 Hz	1 Hz
Consumo d'aria per ciclo Cycle air consumption	132 cm ³	208 cm ³	257 cm ³	371 cm ³	940 cm ³
Tempo di chiusura senza carico Closing time without load	0.05 s	0.1 s	0.15 s	0.2 s	0.2 s
Ripetibilità Repetition accuracy	0.04 mm	0.04 mm	0.04 mm	0.04 mm	0.04 mm
Peso Weight	1650 g	2100 g	2600 g	3200 g	3800 g

Forza di serraggio

I grafici mostrano la forza per griffa espressa dalla pinza in funzione della pressione, del braccio Z e del disassamento del punto di presa X.

Gripping force

The graphs show the gripping force on each jaw, as a function of the operating pressure, the gripping tool length Z and the overhanging X.

La forza indicata in questi grafici è riferita alla singola griffa. La forza totale è il doppio.

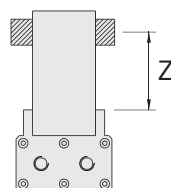

The force shown in these graphs refers to one jaw. The total force is double.

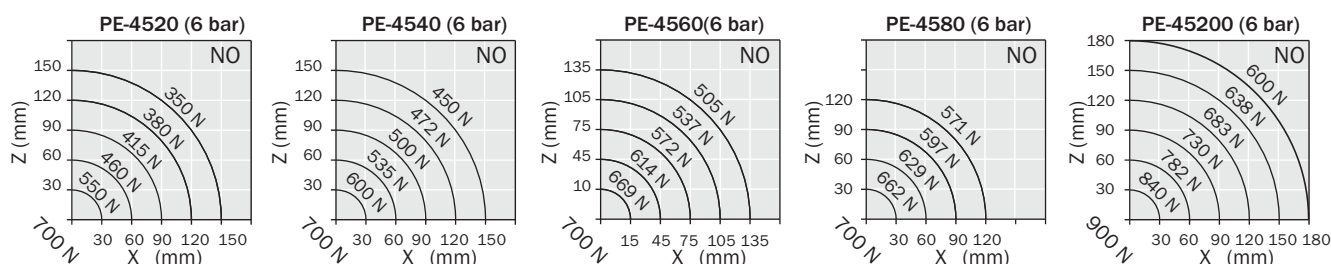
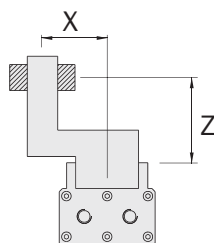
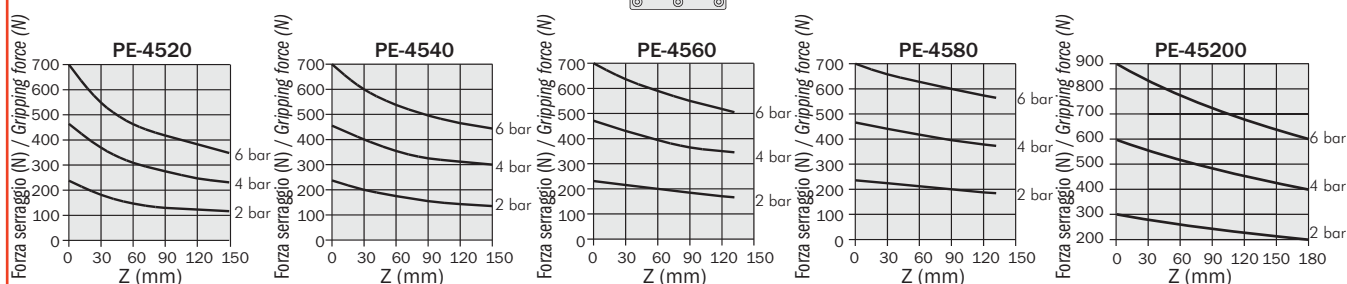

Dimensioni (mm) / Dimensions (mm)

	A	B	C	D	E	F ±0.02	G	H	L	M	N	P	Q	R ±0.02	S ±0.02	T ±0.02	U ±0.02
PE-1610	62	55	26	37	52	44	36	29	13	36	7	11.75	31	26	27	12	7

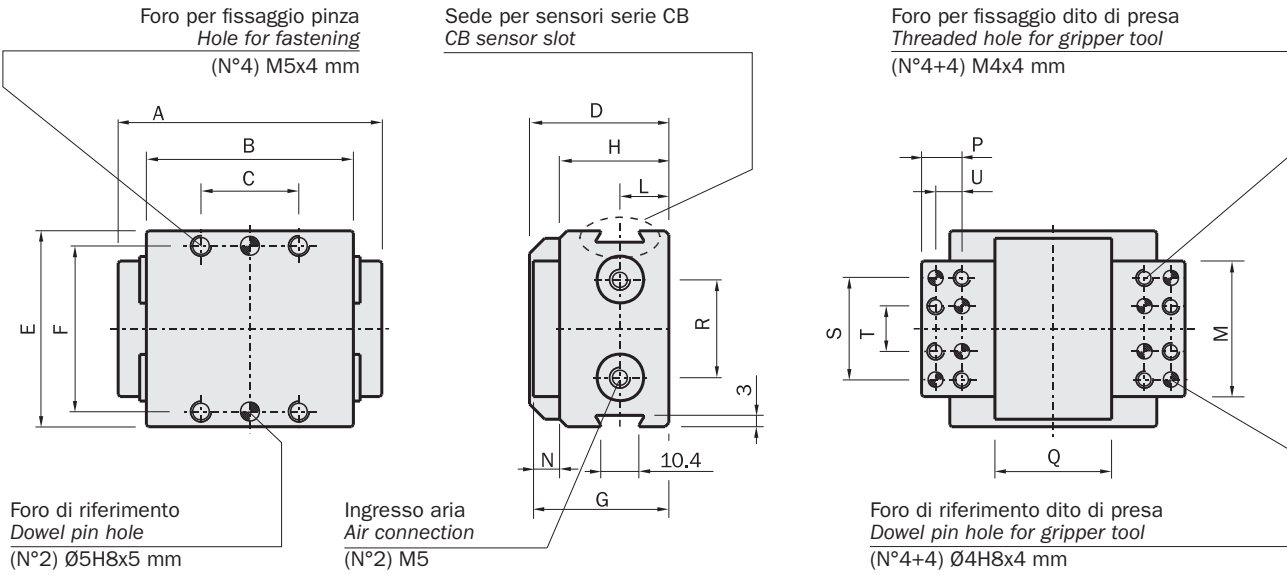

	A	B	C	D	E	F	G ±0.02	H	I	L	M	N	P ±0.02	Q	R	S	T	U	X	Z
PE-1625	65	-	-	26	24	12.5	44	5	-	12	12	48	12	37	29	13	26	52	41.5	14.5
PE-1640	94	-	-	60	24	26.5	44	5	-	8	12	48	10	37	29	13	26	52	63	15
PE-1680	150	-	-	60	24	54.5	44	5	5	8	12	48	10	37	29	13	26	52	99	15
PE-16150	258	-	200	60	24	108.5	44	5	5	8	12	48	10	37	29	13	26	52	172	15
PE-16200	332	280	200	60	24	145.5	44	5	5	8	12	48	10	37	29	13	26	52	221	15

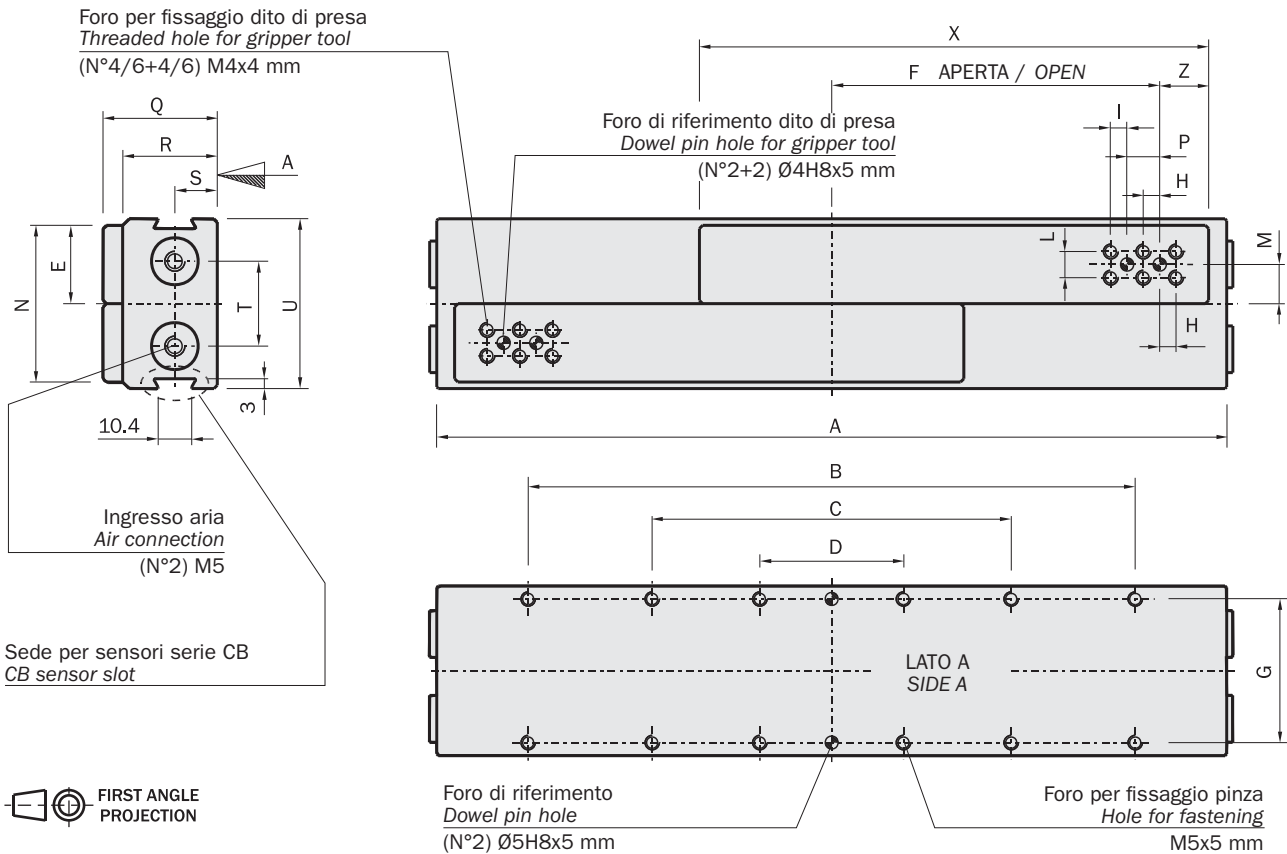

FIRST ANGLE PROJECTION

Fissaggio della pinza

La pinza PE-16... può essere montata in posizione fissa oppure su parti in movimento: in questo caso va considerata la forza d'inerzia cui la pinza ed il suo carico sono sottoposti.

Per fissare la pinza utilizzare i due fori calibrati (A) ed almeno quattro fori filettati (B) presenti sulla base inferiore del corpo pinza.

Lasciare lo spazio necessario per i raccordi dell'aria (C) e per il posizionamento dei sensori nelle cave laterali.

Fixage de la pince

La pince PE-16... peut être montée en position fixe ou sur des pièces mobiles. Dans ce cas il faut considérer la force d'inertie à laquelle la pince et sa charge sont soumises.

Le fixage est obtenu avec deux trous calibrés (A) et quatre trous taraudés (B) placés sur la base inférieure du corps.

Laisser un espace nécessaire pour les raccords de l'air (C) et les capteurs.

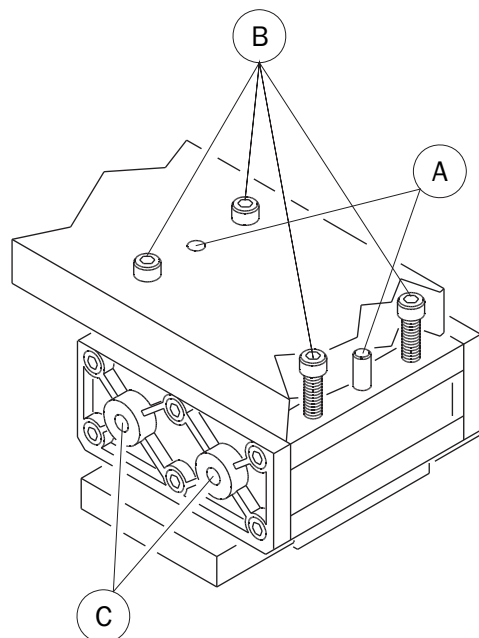

		PE-16...
A	Fiori calibrati Dowel pin holes	Ø5H8x5 mm
B	Fiori filettati Threaded holes	M5x5 mm
C	Fiori filettati per raccordi aria Threaded holes for air fittings	M5

Fissaggio delle estremità di presa

Costruire le dita di presa il più possibile corte e leggere.

Fissarle su ciascuna griffa utilizzando almeno due viti e due spine di centraggio.

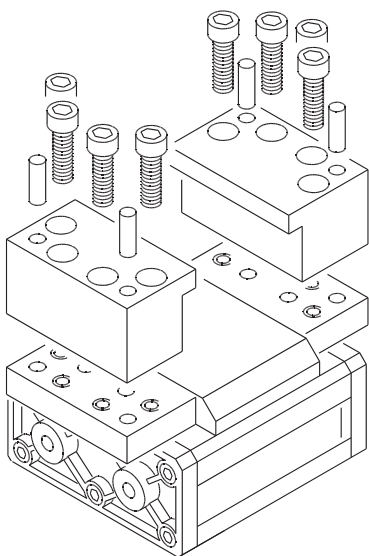

Gripping tool fastening

The gripping tools must be as short and light as possible.

They must be mounted using at least two screws and two dowel pins per jaw.

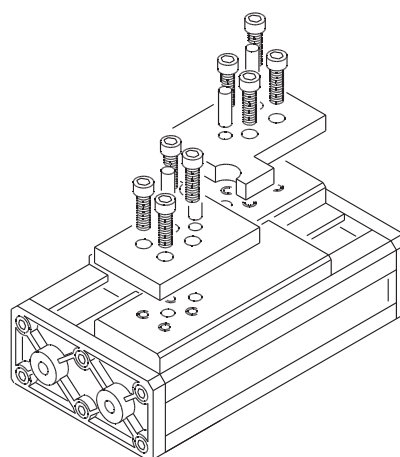

	PE-1610
Fiori calibrati Dowel pin holes	Ø4H8x4 mm
Fiori filettati Threaded holes	M4x4 mm

	PE-1625/40/80/150/200
Fiori calibrati Dowel pin holes	Ø4H8x5 mm
Fiori filettati Threaded holes	M4x4 mm

Dimensioni (mm) / Dimensions (mm)

	A	B	C	D	E ±0.02	F	G ±0.02	H	I	L	M	N	P	Y	R -0.05	S -0.05
PE-2520	90	83.6	-	45	57	48.5	4.5	57	53	19.5	67	18	32	35	14	44
PE-2540	130	123.6	-	45	57	48.5	4.5	57	53	19.5	67	18	32	35	14	44
PE-2560	165	158.6	120	45	57	48.5	4.5	57	53	19.5	67	18	32	35	14	44

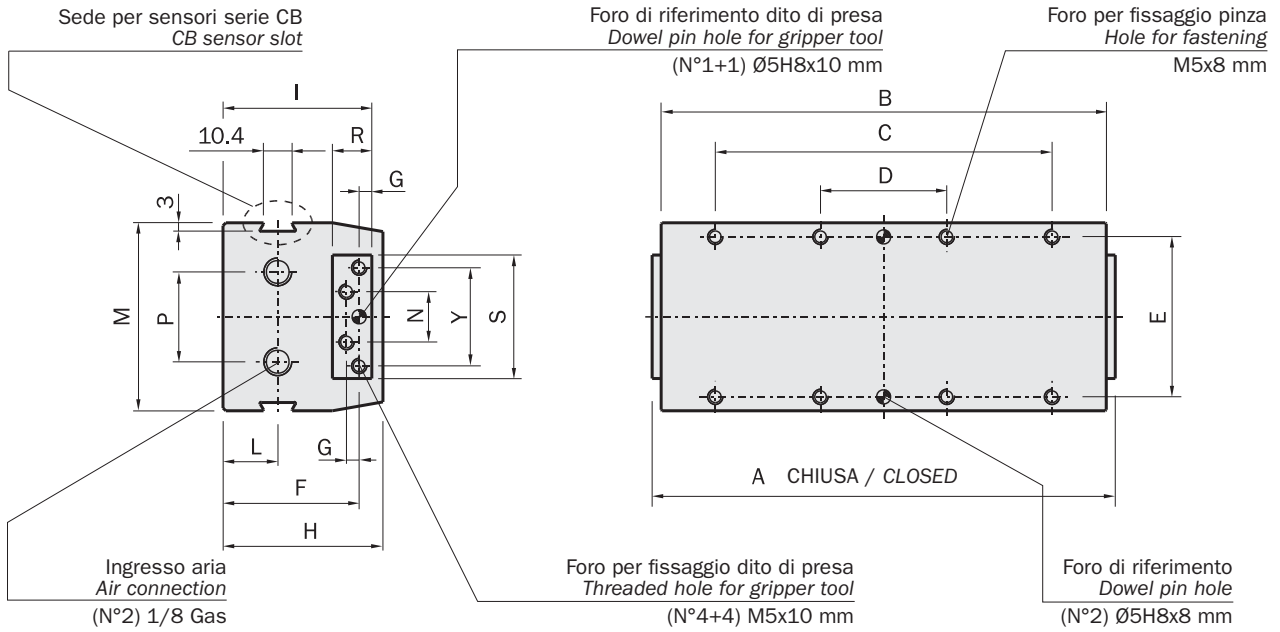

	A	B	C	D	E	F	G	H	L	M	N	P	Y ±0.02	R	S ±0.02	U	X	V
PE-25100	200.6	-	150	45	136	16	64	48.5	39	19.5	32	67	57	75	20	18	32	10
PE-25200	350.6	300	150	45	236	16	64	48.5	39	19.5	32	67	57	150	20	18	32	10

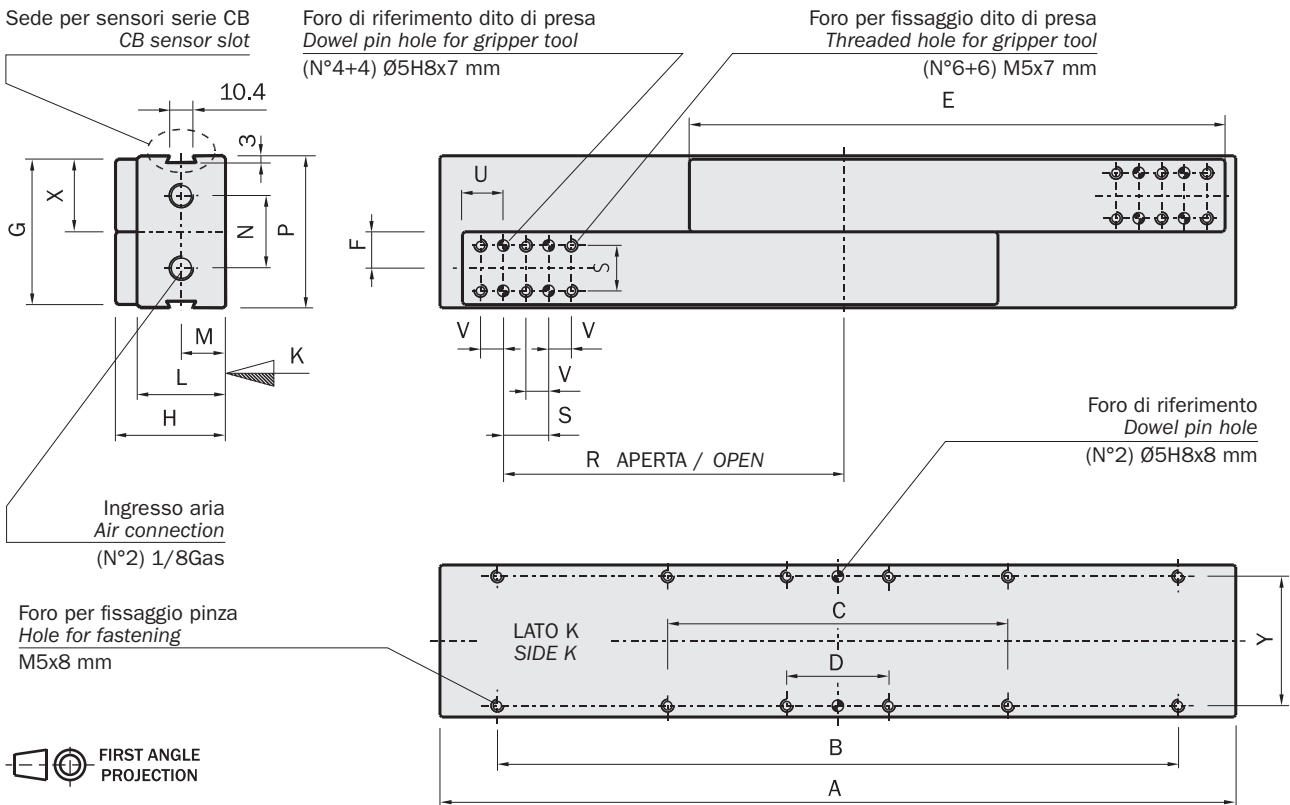

Fissaggio della pinza

La pinza PE-25... può essere montata in posizione fissa oppure su parti in movimento: in questo caso va considerata la forza d'inerzia cui la pinza ed il suo carico sono sottoposti.

Per fissare la pinza utilizzare i due fori calibrati (A) ed almeno quattro fori filettati (B) presenti sulla base inferiore del corpo pinza.

Lasciare lo spazio necessario per i raccordi dell'aria (C) e per il posizionamento dei sensori nelle cave laterali.

Gripper fastening

The gripper PE-25... can be fastened to a static or moving part. When on a moving part, you must pay attention to the forces created by inertia on the gripper and its load.

To fasten the gripper, use the two dowel pin holes (A) and at least four threaded holes (B) on the base of the gripper.

Allow room to mount the air fittings (C) and the sensors.

		PE-25...
A	Fori calibrati Dowel pin holes	Ø5H8x8 mm
B	Fori filettati Threaded holes	M5x8 mm
C	Fori filettati per raccordi aria Threaded holes for air fittings	G1/8

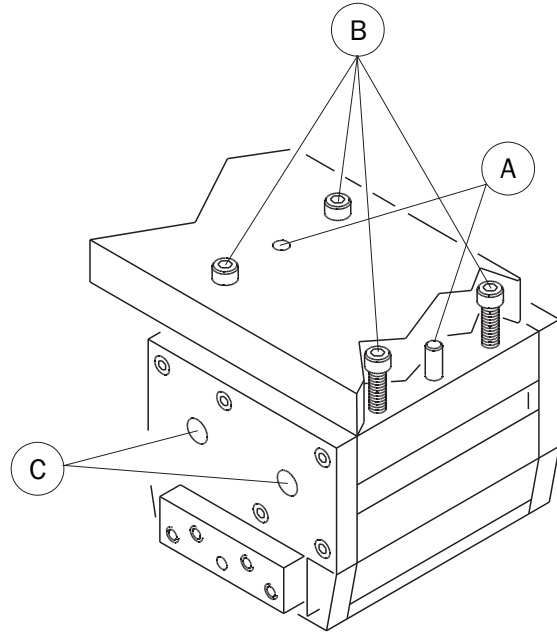

Fissaggio delle estremità di presa

Costruire le dita di presa il più possibile corte e leggere.

Fissarle su ciascuna griffa utilizzando almeno due viti e due spine di centraggio.

Gripping tool fastening

The gripping tools must be as short and light as possible.

They must be mounted using at least two screws and two dowel pins per jaw.

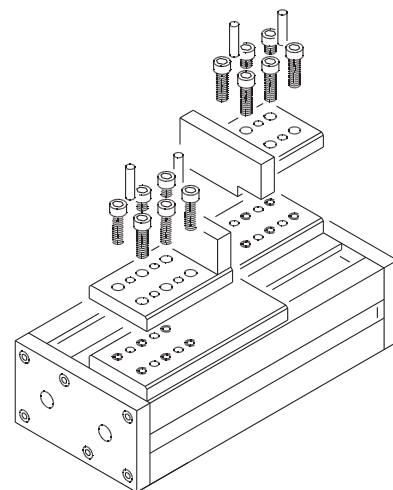
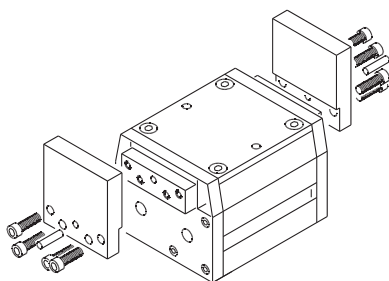

	PE-2520/2540/2560
Fori calibrati Dowel pin holes	Ø5H8x10 mm
Fori filettati Threaded holes	M5x10 mm

	PE-25100/25200
Fori calibrati Dowel pin holes	Ø5H8x7 mm
Fori filettati Threaded holes	M5x7 mm

Dimensioni (mm) / Dimensions (mm)

	A	B	C	D +0 -0.05	E +0.05 -0	F	G	H	L	M	N	P	Q	R +0 -0.05	S ±0.02	T	V	X	K	Z
PE-4520	110	100.6	50	60	10	3	6	47	72.5	60	32	34	28	25	90	83	91	104	85	49
PE-4540	140	128.6	75	60	10	3	6	47	72.5	60	32	34	28	25	90	83	91	104	85	49
PE-4560	170	160.6	90	60	10	3	6	47	72.5	60	32	34	28	25	90	83	91	104	85	49
PE-4580	210	200.6	90	60	10	3	6	47	72.5	60	32	34	28	25	90	83	91	104	85	49

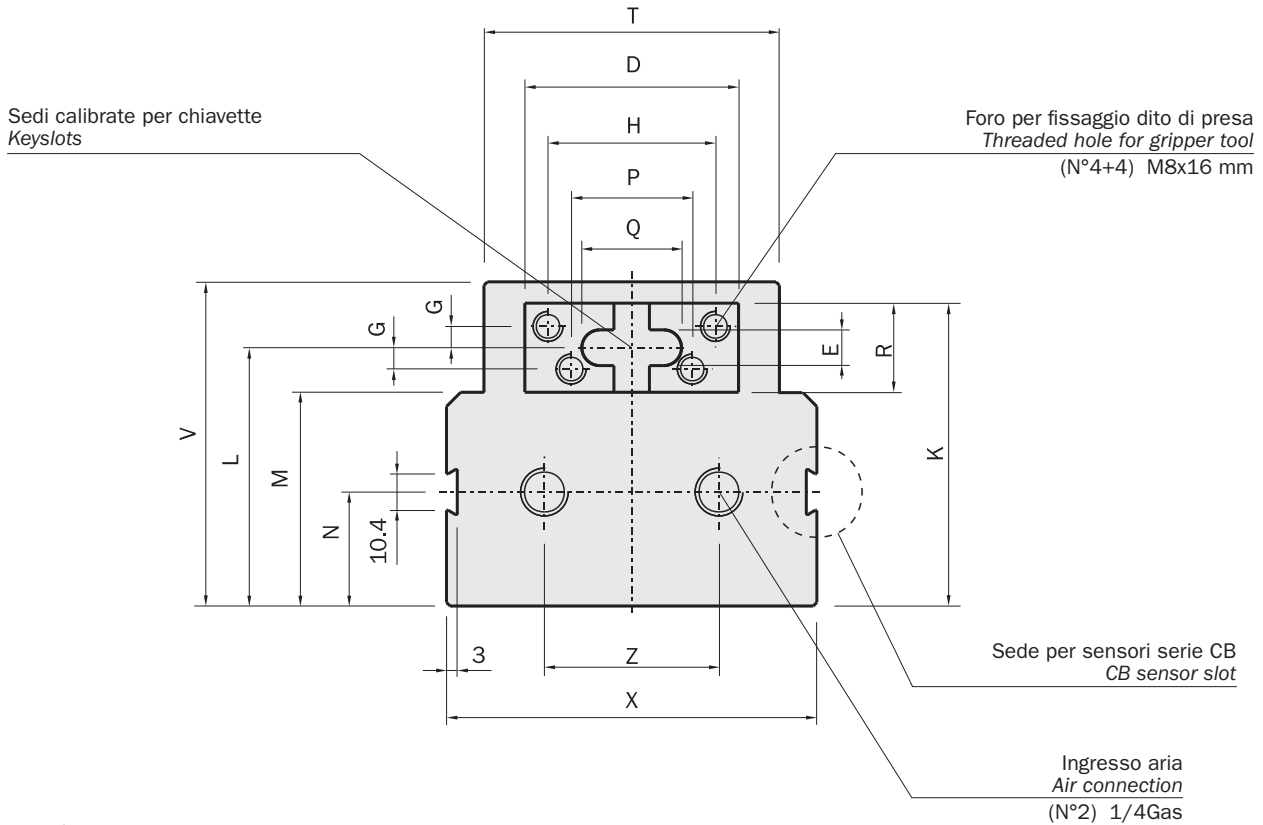
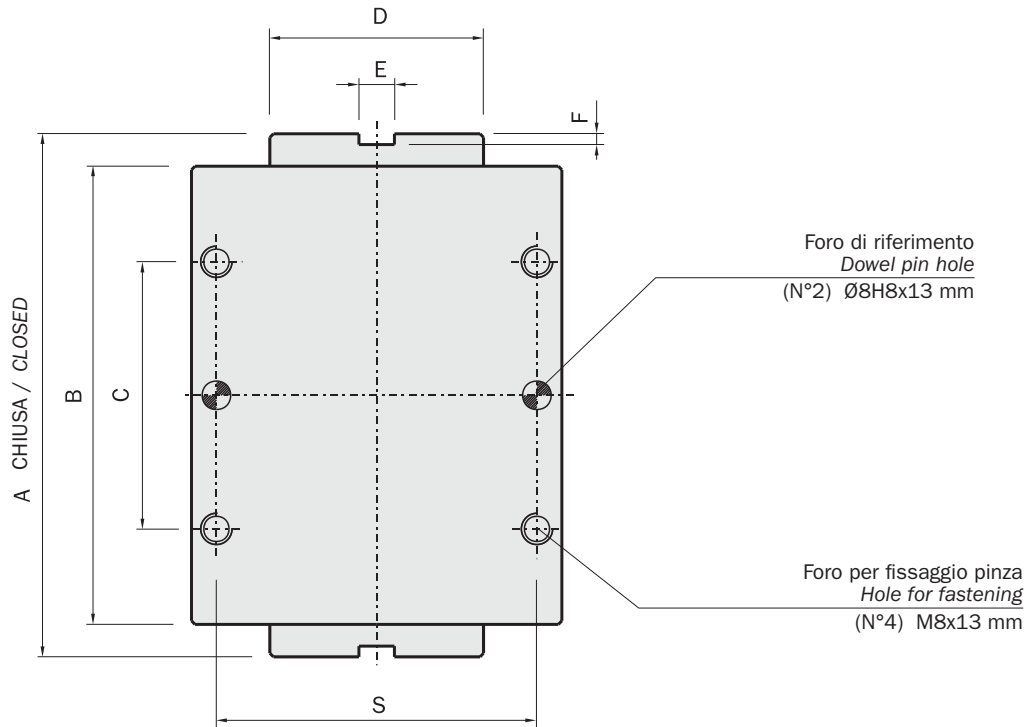

Fissaggio della pinza

La pinza PE-45... può essere montata in posizione fissa oppure su parti in movimento: in questo caso va considerata la forza d'inerzia cui la pinza ed il suo carico sono sottoposti.

Per fissare la pinza utilizzare i due fori calibrati (A) ed almeno quattro fori filettati (B) presenti sulla base inferiore del corpo pinza.

Lasciare lo spazio necessario per i raccordi dell'aria (C) e per il posizionamento dei sensori nelle cave laterali.

Gripper fastening

The gripper PE-45... can be fastened to a static or moving part. When on a moving part, you must pay attention to the forces created by inertia on the gripper and its load.

To fasten the gripper, use the two dowel pin holes (A) and at least four threaded holes (B) on the base of the gripper.

Allow room to mount the air fittings (C) and the sensors.

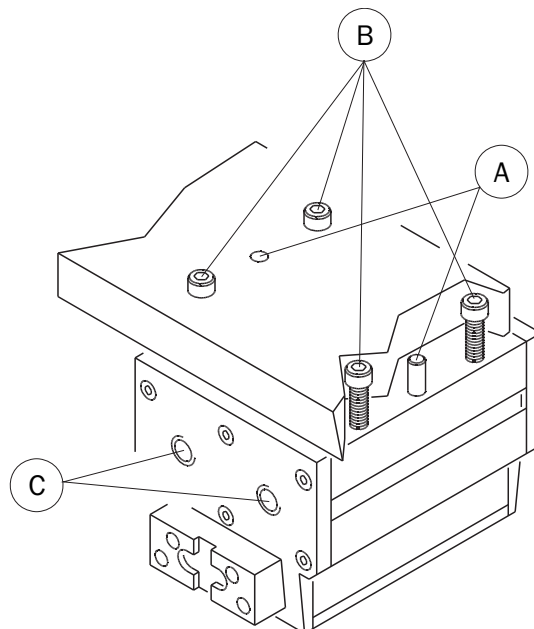

		PE-45...
A	Fori calibrati Dowel pin holes	Ø8H8x13 mm
B	Fori filettati Threaded holes	M8x13 mm
C	Fori filettati per raccordi aria Threaded holes for air fittings	G1/4

Fissaggio delle estremità di presa

Costruire le dita di presa il più possibile corte e leggere.

Fissarle su ciascuna griffa utilizzando almeno due viti delle 4 viti.

Per il centraggio di precisione posizionare le linguette nelle sedi sulle griffe.

Gripping tool fastening

The gripping tools must be as short and light as possible.

They must be mounted using at least two of four screws.

They must be centered using the key-slots on the jaws.

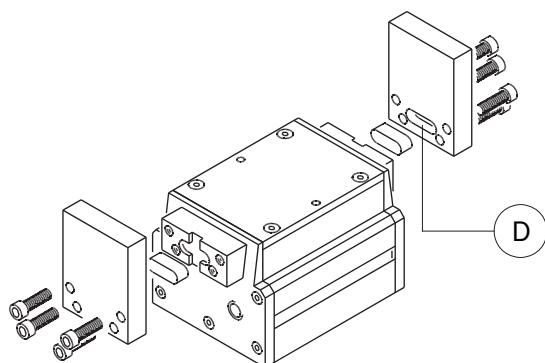

Sede linguetta D Key-slot D	$10^{+0.05} \times 28 \times 3$ mm
Fori filettati Threaded holes	M8x16 mm

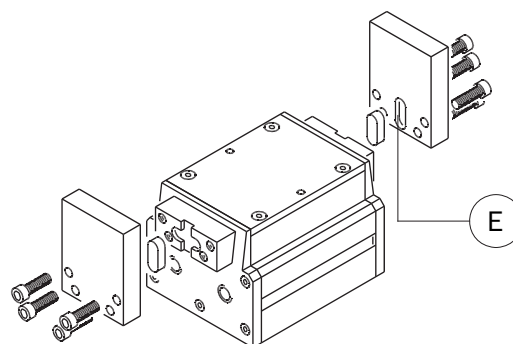

Sede linguetta E Key-slot E	$10^{+0.05} \times 25 \times 3$ mm
Fori filettati Threaded holes	M8x16 mm

Dimensioni (mm) / Dimensions (mm)

PE-45200

FIRST ANGLE
PROJECTION

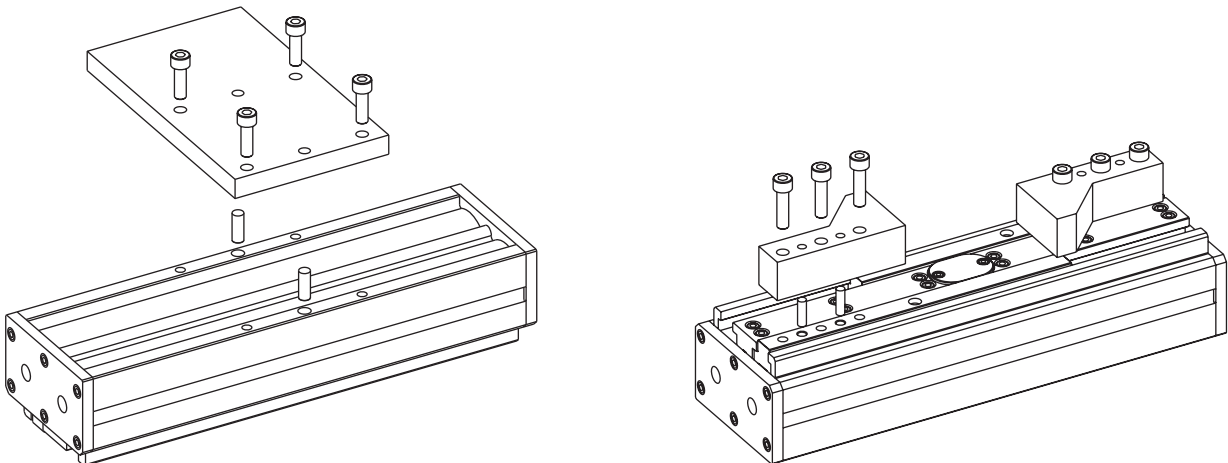
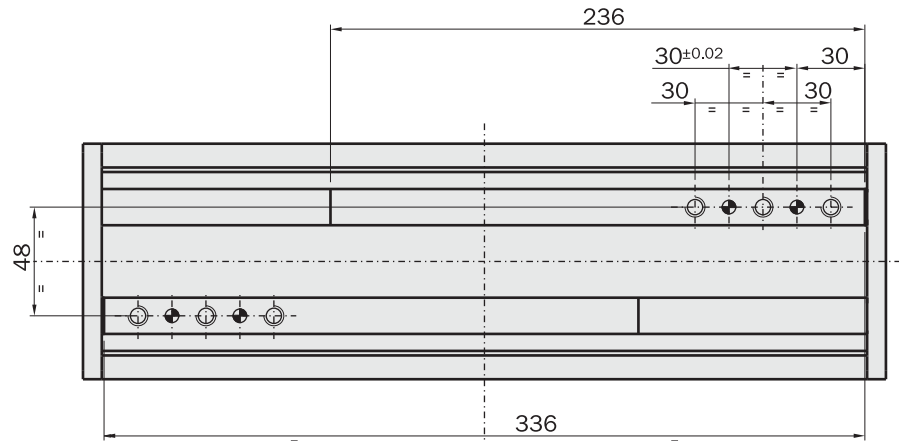
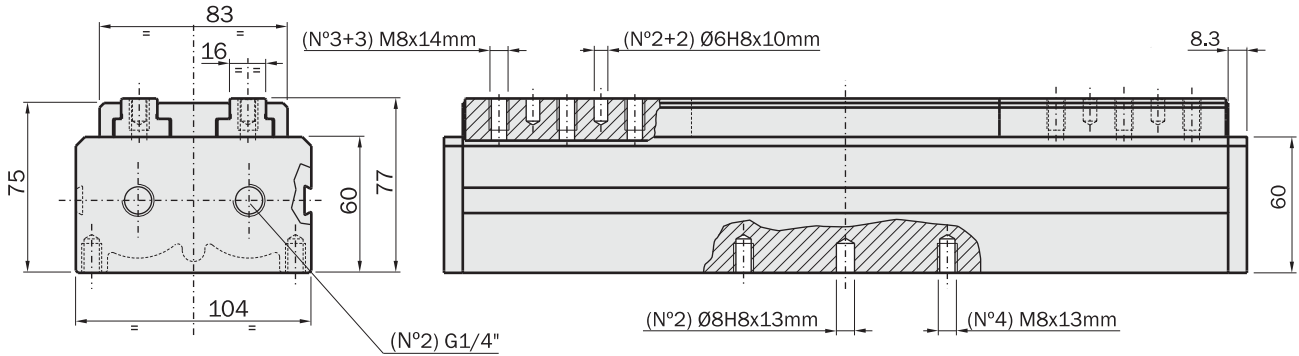
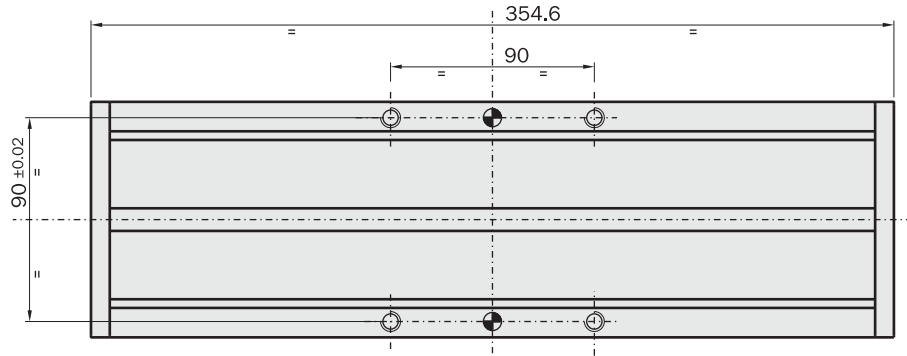

Carichi di sicurezza

Consultare la tabella per i carichi massimi ammissibili. Forze e coppie eccessive possono danneggiare la pinza e causare difficoltà di funzionamento compromettendo la sicurezza dell'operatore.

F_s , $M_x s$, $M_y s$, $M_z s$, sono i carichi massimi ammissibili in condizioni statiche, cioè con le griffe ferme.

F_d , $M_x d$, $M_y d$, $M_z d$, sono i carichi massimi ammissibili in condizioni dinamiche, cioè con le griffe in movimento.

Inoltre sono riportate le masse ammissibili (m) per ogni dito di presa in funzione del tempo di apertura o chiusura. Usare i regolatori di flusso (non forniti) per ottenere la velocità desiderata.

Safety loads

Check the table for maximum permitted loads.

Excessive forces or torques can damage the gripper, cause functioning troubles and endanger the safety of the operator. F_s , $M_x s$, $M_y s$, $M_z s$, are maximum permitted static loads. Static means motionless jaws.

F_d , $M_x d$, $M_y d$, $M_z d$, are maximum permitted dynamic loads. Dynamic means running jaws.

The following tables show the specified maximum loads (m) on each gripping tool as function of closing or opening time. Use flow controllers (not supplied) to get the proper speed.

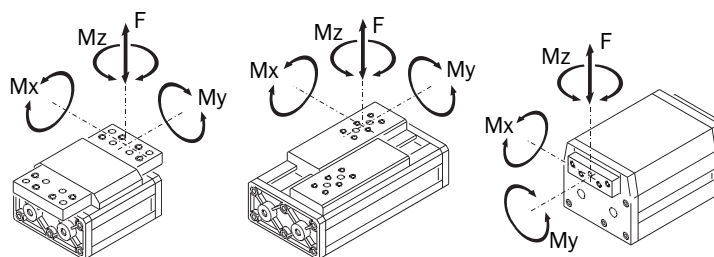

	PE-1610	PE-1625	PE-1640	PE-1680	PE-16150	PE-16200
F_s	48 N	166 N	166 N	163 N	163 N	163 N
$M_x s$	2.4 Nm	5.6 Nm	5.6 Nm	5.6 Nm	5.6 Nm	5.6 Nm
$M_y s$	2.4 Nm	2.9 Nm	2.9 Nm	2.9 Nm	2.9 Nm	2.9 Nm
$M_z s$	2.4 Nm	5.6 Nm	5.6 Nm	5.6 Nm	5.6 Nm	5.6 Nm
F_d	0.48 N	1.7 N	1.7 N	1.6 N	1.6 N	1.6 N
$M_x d$	2.4 Ncm	5.6 Ncm	5.6 Ncm	5.6 Ncm	5.6 Ncm	5.6 Ncm
$M_y d$	2.4 Ncm	2.9 Ncm	2.9 Ncm	2.9 Ncm	2.9 Ncm	2.9 Ncm
$M_z d$	2.4 Ncm	4 Ncm	4 Ncm	4 Ncm	4 Ncm	4 Ncm
m 0.8s	-	166 g	166 g	163 g	163 g	163 g
m 0.5s	-	108 g	108 g	106 g	106 g	106 g
m 0.3s	48 g	93 g	93 g	91 g	-	-
m 0.2s	31 g	83 g	83 g	81 g	-	-
m 0.1s	24 g	60 g	60 g	-	-	-

	PE-2520	PE-2540	PE-2560	PE-25100	PE-25200	
F_s	326 N	326 N	326 N	300 N	300 N	
$M_x s$	14 Nm	15 Nm	18 Nm	21 Nm	21 Nm	
$M_y s$	5 Nm	5 Nm	5 Nm	6 Nm	6 Nm	
$M_z s$	14 Nm	15 Nm	18 Nm	21 Nm	21 Nm	
F_d	3.3 N	3.3 N	3.3 N	3 N	3 N	
$M_x d$	14 Ncm	15 Ncm	18 Ncm	21 Ncm	21 Ncm	
$M_y d$	5 Ncm	5 Ncm	5 Ncm	6 Ncm	6 Ncm	
$M_z d$	14 Ncm	15 Ncm	18 Ncm	21 Ncm	21 Ncm	
m 0.5s	-	-	-	300 g	300 g	
m 0.3s	326 g	326 g	326 g	195 g	195 g	
m 0.2s	212 g	212 g	212 g	150 g	150 g	
m 0.1s	163 g	163 g	163 g	105 g	-	

	PE-4520	PE-4540	PE-4560	PE-4580	PE-45200	
F_s	730 N	730 N	730 N	730 N	700 N	
$M_x s$	69 Nm	86 Nm	88 Nm	88 Nm	110 Nm	
$M_y s$	41 Nm	41 Nm	41 Nm	41 Nm	40 Nm	
$M_z s$	69 Nm	86 Nm	88 Nm	88 Nm	110 Nm	
F_d	7 N	7 N	7 N	7 N	14 N	
$M_x d$	69 Ncm	86 Ncm	88 Ncm	88 Ncm	110 Ncm	
$M_y d$	41 Ncm	41 Ncm	41 Ncm	41 Ncm	80 Ncm	
$M_z d$	69 Ncm	86 Ncm	88 Ncm	88 Ncm	110 Ncm	
m 0.5s	-	-	-	700 g	1400 g	
m 0.4s	-	700 g	700 g	450 g	1000 g	
m 0.3s	700 g	450 g	450 g	350 g	700 g	
m 0.2s	450 g	350 g	350 g	300 g	500 g	
m 0.1s	350 g	300 g	300 g	-	-	

Sensori

Il rilevamento della posizione di lavoro è affidato a uno o più sensori magnetici di prossimità (opzionali), che rilevano la posizione attraverso i magneti sui pistoni. Quindi, per un corretto funzionamento, è da evitare l'impiego in presenza di forti campi magnetici od in prossimità di grosse masse di materiale ferromagnetico.

Per il montaggio:

- 1- Inserire il dado quadrato (A) nella propria sede sull'adattatore "S 00".
- 2- Infilare l'adattatore nella guida sulla pinza.
- 3- Calzare il sensore sull'adattatore.
- 4- Fare scorrere nella guida fino a raggiungere la posizione di lavoro desiderata (led acceso).
- 5- Bloccare con la vite (B), facendo attenzione a non serrarla eccessivamente.

Sensors

The operating position can be checked by magnetic sensors (optional), that detect the magnets on the pistons inside. Therefore a near big mass of ferromagnetic material or intense magnetic fields may cause sensing troubles.

For mounting:

- 1- Insert the square nut (A) in its seat on the "S 00" bracket.
- 2- Insert the bracket into the groove.
- 3- Insert the sensor into the bracket.
- 4- Run the sensor until the lamp is on.
- 5- Lock the bracket with the screw (B) but don't over-tighten it.

	CB3N2-G	CB3M2-G
Tensione di alimentazione (DC) DC power supply	6 ÷ max 30 V	
Tipo sensore Sensor type	PNP	NPN
Massima corrente Max current	250 mA	
Potenza Power	6 W	
Temperatura di esercizio Operating temperature	-10° ÷ +70° C.	
Tempo di eccitazione Response time "ON"	0.8 µs	
Tempo di diseccitazione Response time "OFF"	0.3 µs	
Valore di eccitazione Operate point	40 GAUSS	
Valore di diseccitazione Dropout point	35 GAUSS	
Vita elettrica Life time	10 ⁹ IMP	
Resistenza di contatto Contact resistance	-	
Resistenza agli urti Max admitted shock	30 G	
Grado di protezione Environmental protection degree	IP 67	
Caduta di tensione diretta Voltage drop	1 V	

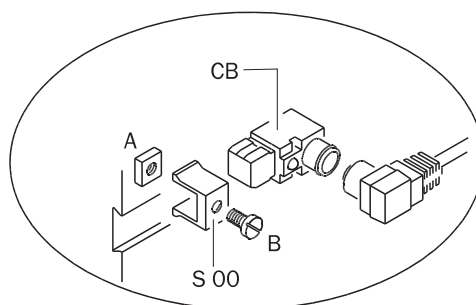
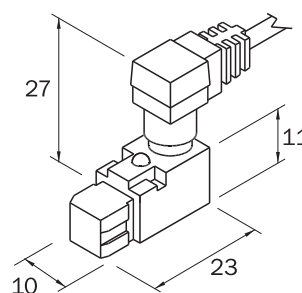
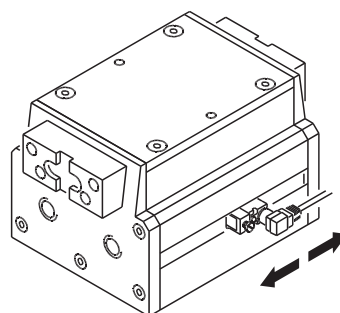

Elenco delle parti / Parts list

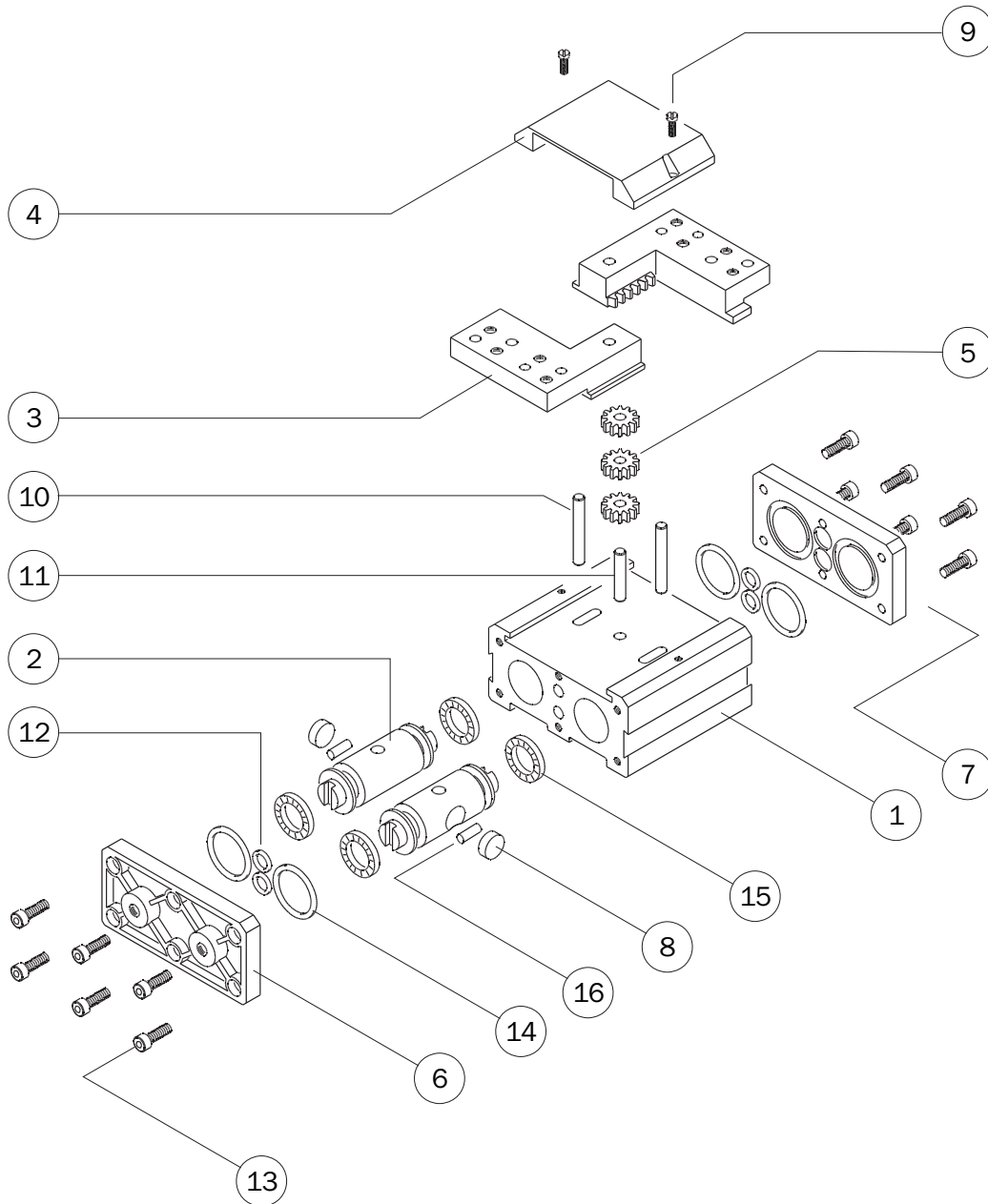

		PE-1610		
1	Corpo pinza	PE-1610-01	Gripper housing	1
2	Pistone	PE-1610-02	Piston	2
3	Griffa	PE-1610-03	Jaw	3
4	Protezione	PE-1610-04	Protection	4
5	Pignone	PE-1640-06	Pinion	5
6	Testata aperta	PE-1680-05A	Open end plate	6
7	Testata chiusa	PE-1680-05C	Closed end plate	7
8	Inserto portamagnete	PE-1610-05	Magnet housing	8
9	Vite	VITE-056 (M2x5 mm DIN84A INOX A2)	Screw	9
10	Spina di riferimento	SPINA-012 (Ø4x20 mm DIN6325)	Dowel pin	10
11	Spina di riferimento	SPINA-019 (Ø4x14 mm DIN6325)	Dowel pin	11
12	O-Ring	GUAR-029 (Ø1.78x4.48)	O-Ring	12
13	Vite	VITE-031 (M3x8 mm DIN912 INOX A2)	Screw	13
14	O-Ring	GUAR-023 (Ø1.78x15.6)	O-Ring	14
15	Guarnizione dinamica	GUAR-002P (16x9x2.5)	Dynamic gasket	15
16	Magnete	PAR-06-7	Magnet	16

Elenco delle parti / Part list

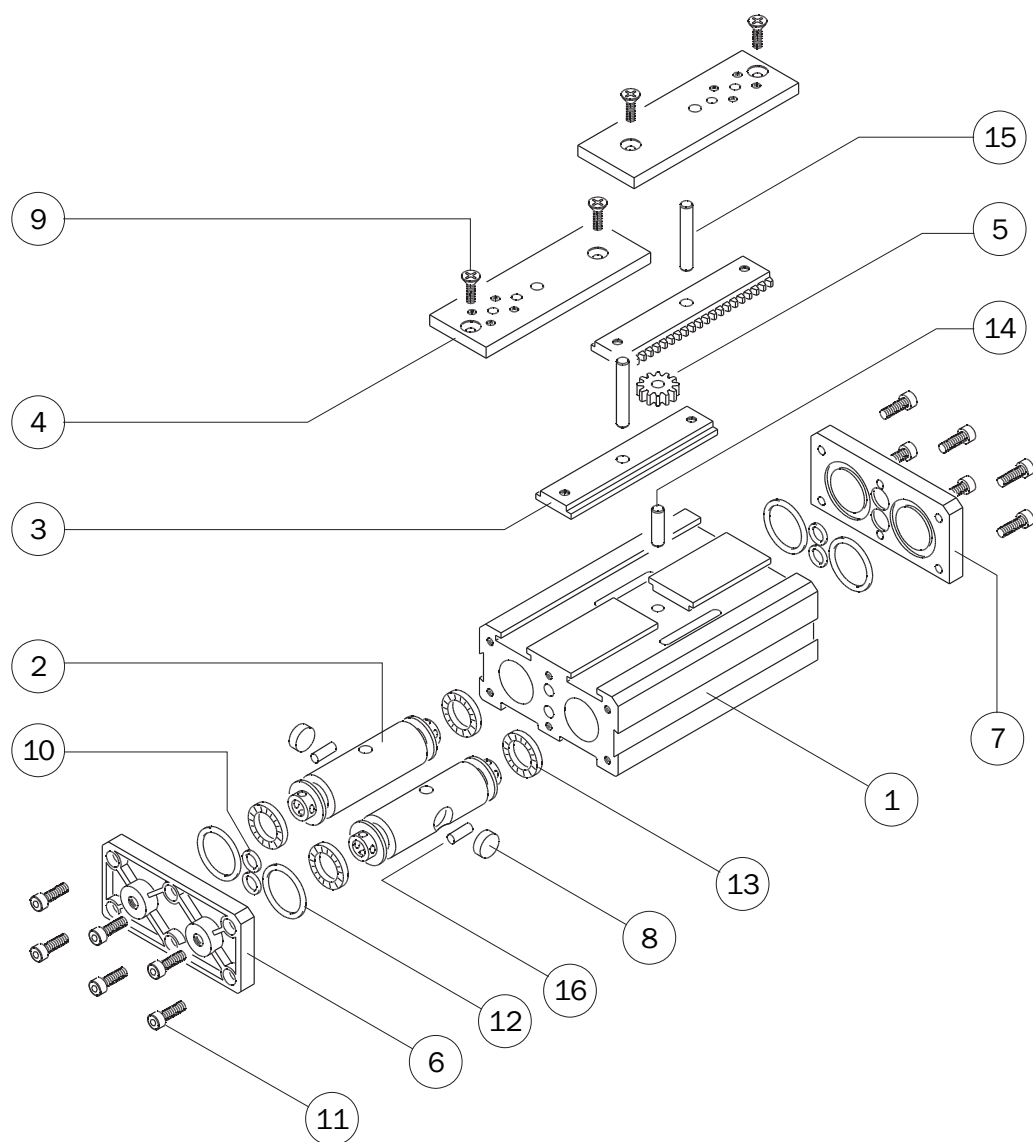

		PE-1625	PE-1640		
1	Corpo pinza	PE-1625-01	PE-1640-01	Gripper housing	1
2	Pistone	PE-1625-02	PE-1640-02	Piston	2
3	Cremagliera	PE-1625-03	PE-1640-03	Rack	3
4	Griffa	PE-1625-04	PE-1640-04	Jaw	4
5	Pignone	PE-16150-06		Pinion	5
6	Testata aperta	PE-1680-05A		Open end plate	6
7	Testata chiusa	PE-1680-05C		Closed end plate	7
8	Inserto portamagnete	PE-1610-05		Magnet housing	8
9	Vite	VITE-012 (M3x10 mm DIN965A INOX A2)		Screw	9
10	O-Ring	GUAR-029 (Ø1.78x4.48)		O-Ring	10
11	Vite	VITE-031 (M3x8 mm DIN912 INOX A2)		Screw	11
12	O-Ring	GUAR-023 (Ø1.78x15.6)		O-Ring	12
13	Guarnizione dinamica	GUAR-002P (16x9x2.5)		Dynamic gasket	13
14	Spina di riferimento	SPINA-034 (Ø4x8 mm DIN6325)		Dowel pin	14
15	Spina di riferimento	SPINA-033 (Ø4x25 mm DIN6325)		Dowel pin	15
16	Magnete	PAR-06-7		Magnet	16

Elenco delle parti / Part list

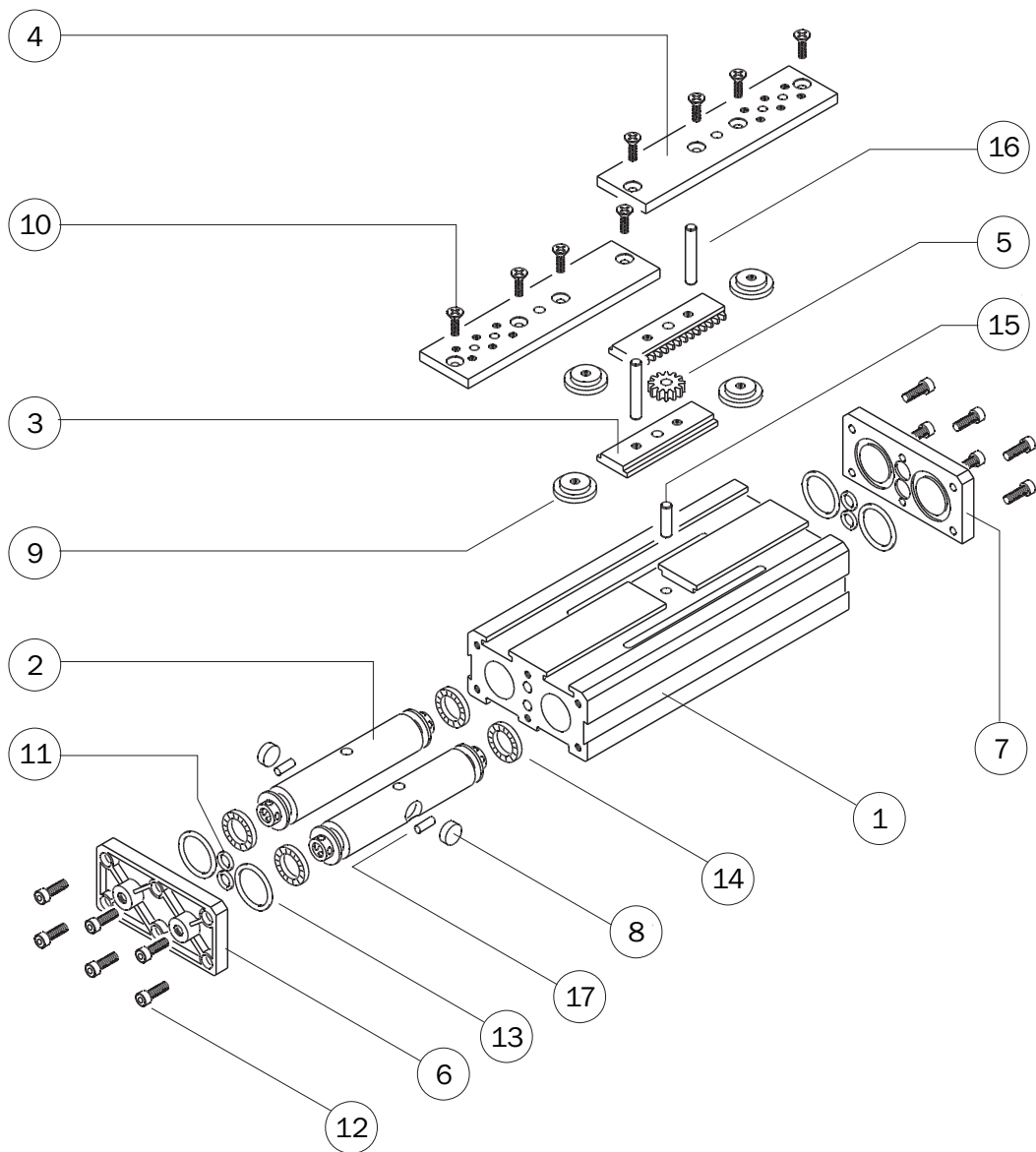

		PE-1680	PE-16150	PE-16200		
1	Corpo pinza	PE-1680-01	PE-16150-01	PE-16200-01	Gripper housing	1
2	Pistone	PE-1680-02	PE-16150-02	PE-16200-02	Piston	2
3	Cremagliera	PE-1680-03	PE-16150-03	PE-16200-03	Rack	3
4	Griffa	PE-1680-04	PE-16150-04	PE-16200-04	Jaw	4
5	Pignone		PE-16150-06		Pinion	5
6	Testata aperta		PE-1680-05A		Open end plate	6
7	Testata chiusa		PE-1680-05C		Closed end plate	7
8	Insero portamagnete		PE-1610-05		Magnet housing	8
9	Pattino guida		PE-1680-08		Guide profile	9
10	Vite	VITE-012 (M3x10 mm DIN965A INOX A2)			Screw	10
11	O-Ring	GUAR-029 (Ø1.78x4.48)			O-Ring	11
12	Vite	VITE-031 (M3x8 mm DIN912 INOX A2)			Screw	12
13	O-Ring	GUAR-023 (Ø1.78x15.6)			O-Ring	13
14	Guarnizione dinamica	GUAR-002P (16x9x2.5)			Dynamic gasket	14
15	Spina di riferimento	SPINA-034 (Ø4x8 mm DIN6325)			Dowel pin	15
16	Spina di riferimento	SPINA-033 (Ø4x25 mm DIN6325)			Dowel pin	16
17	Magnete	PAR-06-7			Magnet	17

Elenco delle parti / Part list

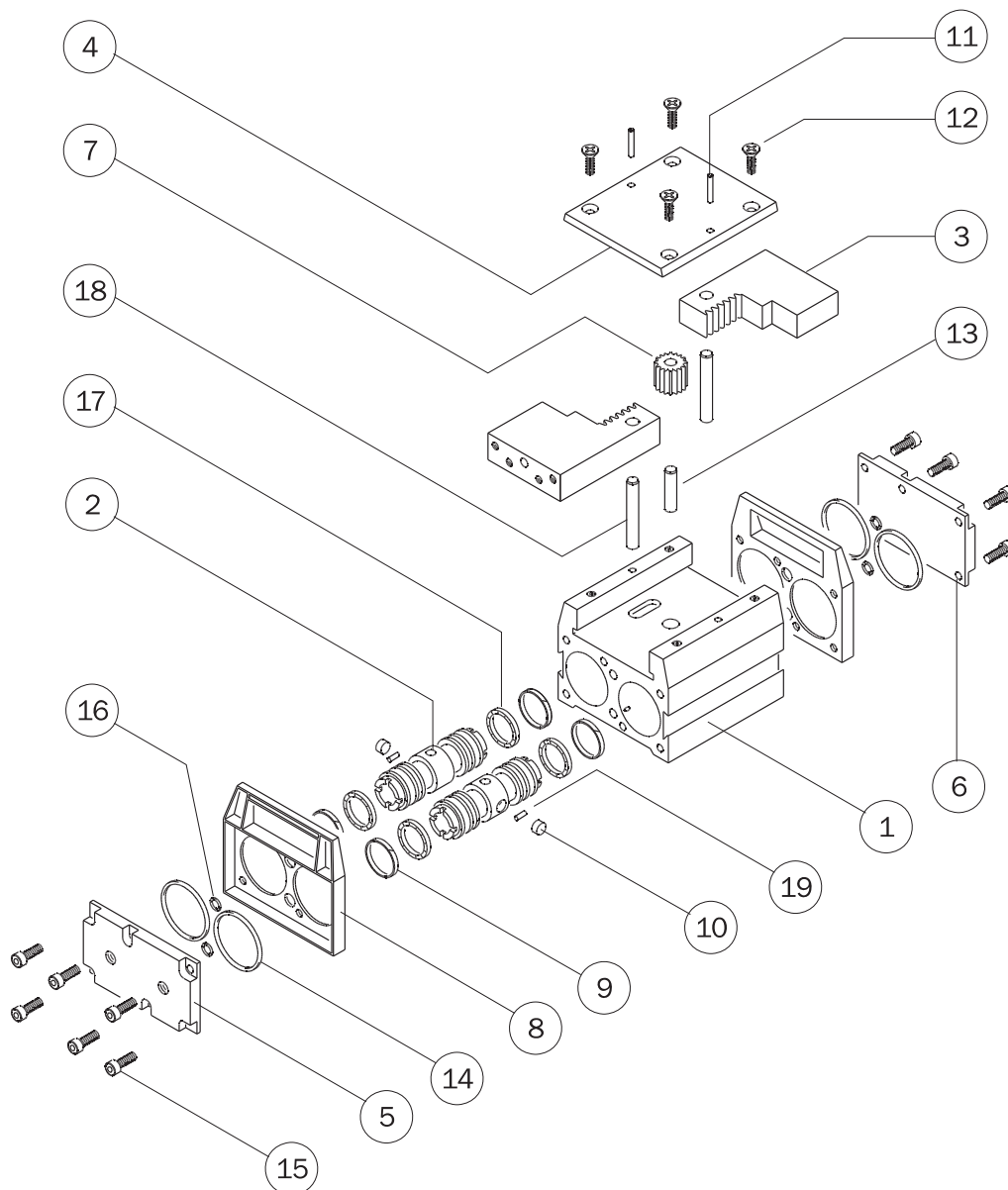

		PE-2520	PE-2540	PE-2560		
1	Corpo pinza	PE-2520-01	PE-2540-01	PE-2560-01	Gripper housing	1
2	Pistone	PE-2520-02	PE-2540-02	PE-2560-02	Piston	2
3	Griffa	PE-2520-03	PE-2540-03	PE-2560-03	Jaw	3
4	Copertura	PE-2520-04	PE-2540-04	PE-2560-04	Cover plate	4
5	Testata aperta		PE-2520-05A		Open end plate	5
6	Testata chiusa		PE-2520-05C		Closed end plate	6
7	Pignone		PE-2520-07		Pinion	7
8	Profilo		PE-2520-08		Seal profile	8
9	Fascia di guida		PE-25100-08		Piston guidance ring	9
10	Inserito portamagnete		PE-2520-09		Magnet housing	10
11	Spina di riferimento		SPINA-016 (Ø4x10 mm DIN6325)		Dowel pin	11
12	Vite		VITE-390 (M4x8 mm DIN84A INOX A2)		Screw	12
13	Spina di riferimento		SPINA-018 (Ø8x20 mm DIN5402)		Dowel pin	13
14	O-Ring		GUAR-030 (Ø1.78x25.12)		O-Ring	14
15	Vite		VITE-020 (M4x10 mm DIN912 INOX A2)		Screw	15
16	O-Ring		GUAR-029 (Ø1.78x4.48)		O-Ring	16
17	Guarnizione dinamica		GUAR-003M (25x18x2.4)		Dynamic gasket	17
18	Spina di riferimento		SPINA-032 (Ø6x40 mm DIN6325)		Dowel pin	18
19	Magnete		PAR-06-7		Magnet	19

Elenco delle parti / Part list

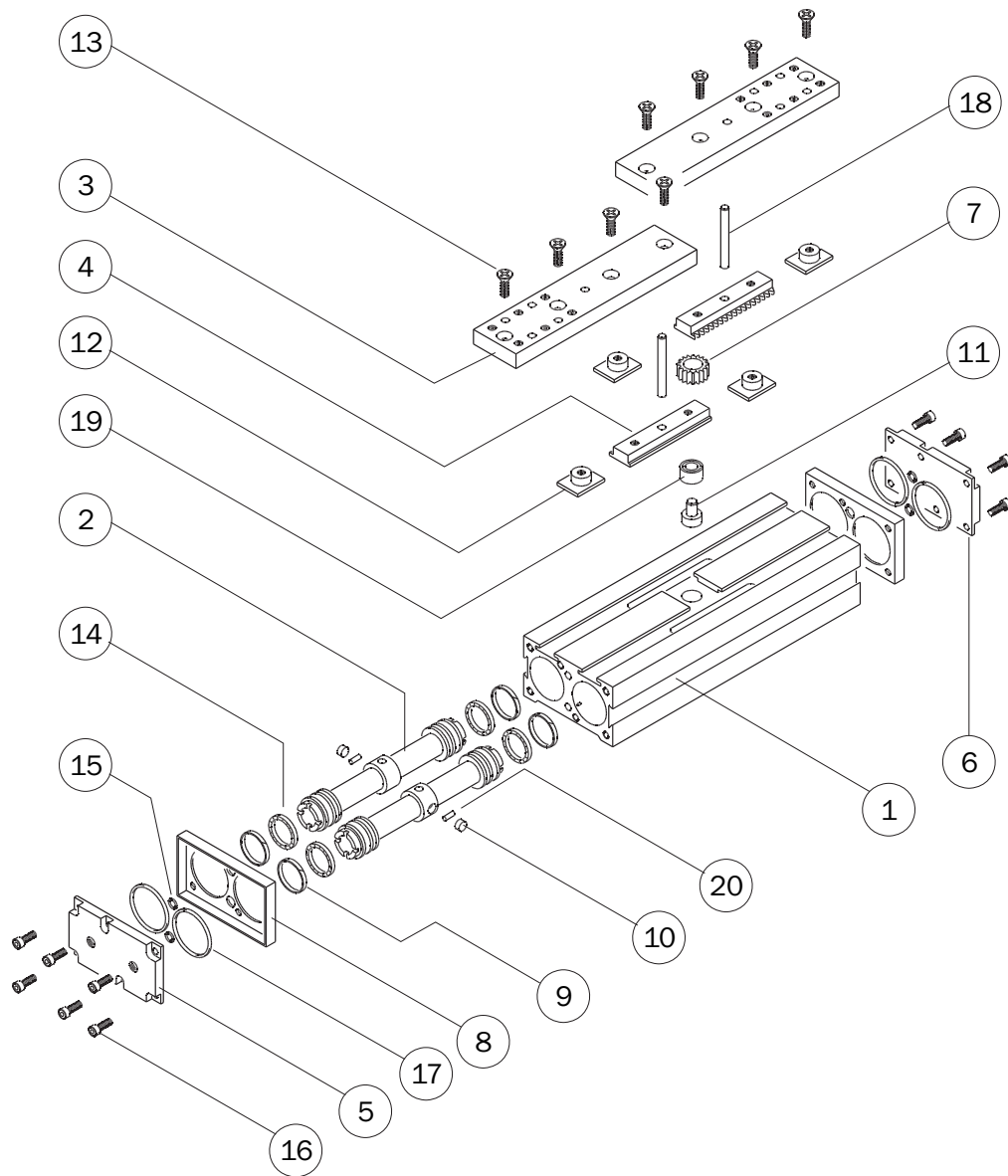

		PE-25100	PE-25200		
1	Corpo pinza	PE-25100-01	PE-25200-01	Gripper housing	1
2	Pistone	PE-25100-02	PE-25200-02	Piston	2
3	Griffa	PE-25100-03	PE-25200-03	Jaw	3
4	Cremagliera	PE-25100-07	PE-25200-07	Rack	4
5	Testata aperta		PE-2520-05A	Open end plate	5
6	Testata chiusa		PE-2520-05C	Closed end plate	6
7	Pignone		PE-25100-05	Pinion	7
8	Profilo		PS-0025-P09	Seal profile	8
9	Fascia di guida		PE-25100-08	Piston guidance ring	9
10	Inserto portamagnete		PE-2520-09	Magnet housing	10
11	Perno		PE-25100-10	Pin	11
12	Pattino guida		PE-25100-09	Guide profile	12
13	Vite		VITE-030 (M5x12 mm DIN965 INOX A2)	Screw	13
14	Guarnizione dinamica		GUAR-003M (25x18x2.4)	Dynamic gasket	14
15	O-Ring		GUAR-029 (Ø1.78x4.48)	O-Ring	15
16	Vite		VITE-020 (M4x10 mm DIN912 INOX A2)	Screw	16
17	O-Ring		GUAR-030 (Ø1.78x25.12)	O-Ring	17
18	Spina di riferimento		SPINA-030 (Ø6x36 mm DIN6325)	Dowel pin	18
19	Cuscinetto radiale		CUSC-002 (Ø3x10x4)	Radial ball bushing	19
20	Magnete		PAR-06-7	Magnet	20

Elenco delle parti / Part list

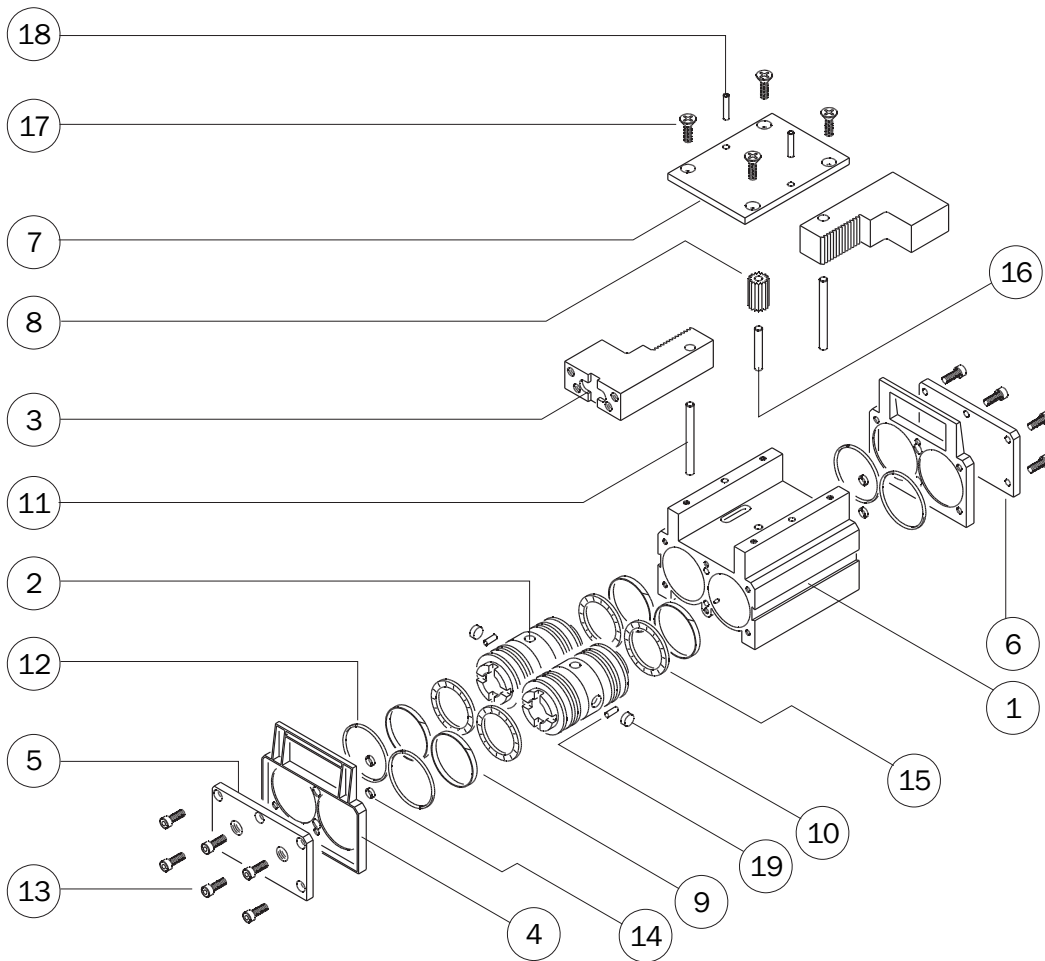

		PE-4520	PE-4540	PE-4560	PE-4580		
1	Corpo pinza	PE-4520-01	PE-4540-01	PE-4560-01	PE-4580-01	Gripper housing	1
2	Pistone	PE-4520-02	PE-4540-02	PE-4560-02	PE-4580-02	Piston	2
3	Griffa	PE-4520-03	PE-4540-03	PE-4560-03	PE-4580-03	Jaw	3
4	Profilo	PE-4520-04				Seal profile	4
5	Testata aperta	PE-4520-05A				Open end plate	5
6	Testata chiusa	PE-4520-05A				Closed end plate	6
7	Copertura	PE-4520-06	PE-4540-04	PE-4560-04	PE-4580-04	Cover plate	7
8	Pignone	PE-4520-09				Pinion	8
9	Fascia di guida	PE-45120-08				Piston guidance ring	9
10	Inserto portamagnete	PE-4520-10				Magnet housing	10
11	Spina di riferimento	SPINA-029 (Ø8x40 mm DIN6325)				Dowel pin	11
12	O-Ring	GUAR-028 (Ø1.78x44.17)				O-Ring	12
13	Vite	VITE-027 (M5x10 mm DIN912 INOX A2)				Screw	13
14	O-Ring	GUAR-029 (Ø1.78x4.48)				O-Ring	14
15	Guarnizione dinamica	GUAR-026P (45x36x3)				Dynamic gasket	15
16	Spina di riferimento	SPINA-030 (Ø6x36 mm DIN6325)				Dowel pin	16
17	Vite	VITE-026 (M5x16 mm DIN965A INOX A2)				Screw	17
18	Spina di riferimento	SPINA-028 (Ø5x10 mm DIN6325)				Dowel pin	18
19	Magnete	PAR-06-7				Magnet	19

Elenco delle parti / Part list

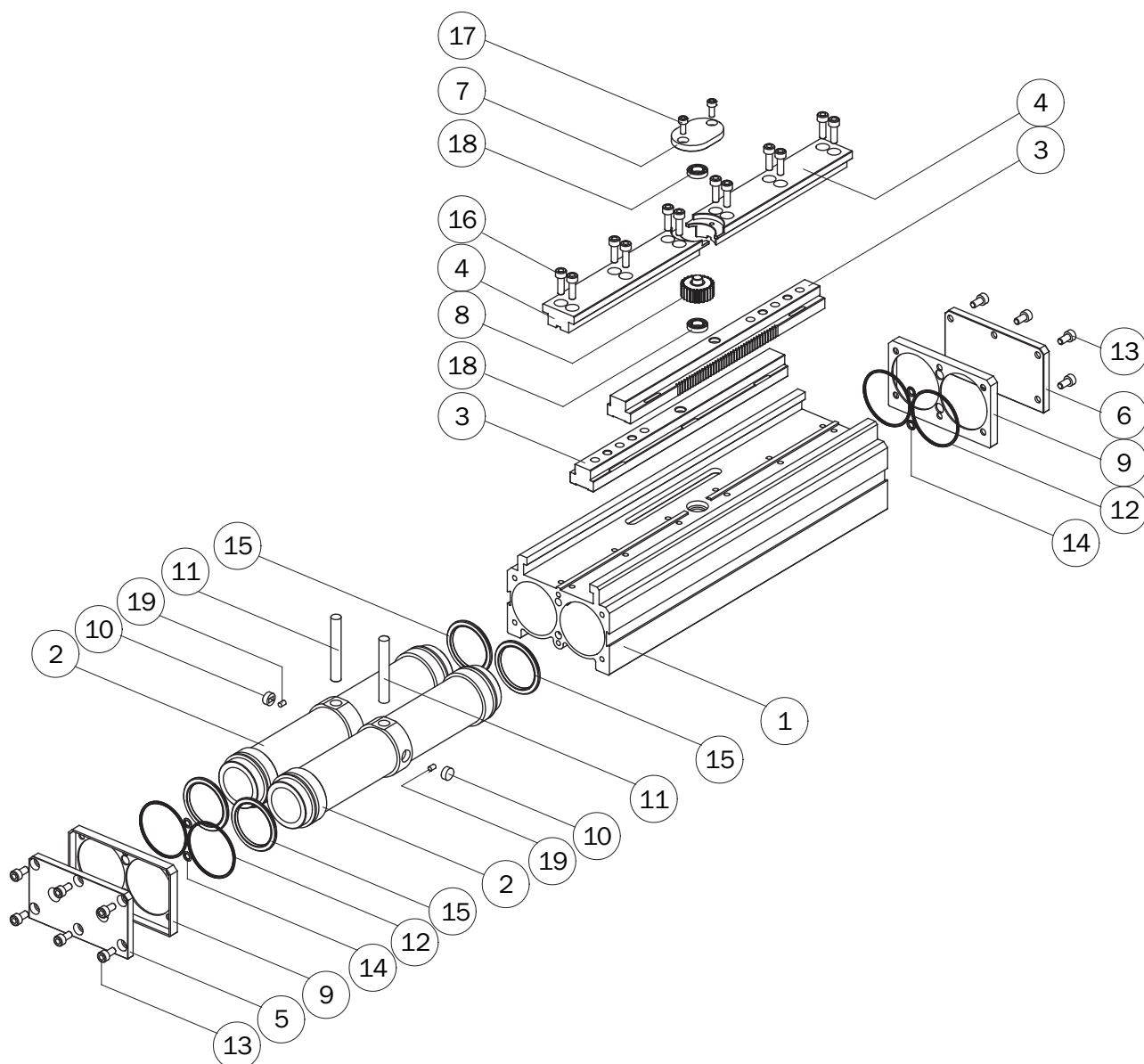

		PE-45200		
1	Corpo pinza	PE-45200-01	Gripper housing	1
2	Pistone	PE-45200-02	Piston	2
3	Griffa	PE-45200-03	Jaw	3
4	Guida centrale	PE-45200-04	Central guidance	4
5	Testata aperta	PE-4520-05A	Open end plate	5
6	Testata chiusa	PE-4520-05C	Closed end plate	6
7	Piastra supporto cuscinetto	PE-45200-06	Bearing cover	7
8	Pignone	PE-45200-09	Pinion	8
9	Profilo	PS-0045-P09	Seal profil	9
10	Inserto portamagnete	PE-4520-10	Magnet housing	10
11	Spina di riferimento	SPINA-058 (Ø8x60 mm DIN6325)	Dowel pin	11
12	O-Ring	GUAR-028 (Ø1.78x44.17)	O-Ring	12
13	Vite	VITE-027 (M5x10 mm DIN912 INOX A2)	Screw	13
14	O-Ring	GUAR-029 (Ø1.78x4.48)	O-Ring	14
15	Guarnizione dinamica	GUAR-026P (45x36x3)	Dynamic gasket	15
16	Vite	VITE-015 (M5x16 mm DIN912 INOX A2)	Screw	16
17	Vite	VITE-020 (M4x10 mm DIN912 INOX A2)	Screw	17
18	Cuscinetto radiale	CUSC-011 (Ø8xØ16x4 ISB 618/B)	Ball bearing	18
19	Magnete	PAR-06-7	Magnet	19

Connessione pneumatica

La pinza si alimenta con aria compressa dai fori laterali (P e R) montandovi i raccordi dell'aria ed i relativi tubi (non forniti).

La pinza è azionata con aria compressa filtrata (5÷40 µm) non necessariamente lubrificata.

La scelta iniziale, lubrificata o non lubrificata, deve essere mantenuta per tutta la vita della pinza.

L'impianto pneumatico deve essere pressurizzato gradualmente, per evitare movimenti incontrollati.

Compressed air feeding

The compressed air feeding is accomplished on the lateral air ports (P and R) with fittings and hoses (not supplied).

The compressed air, must be filtered from 5 to 40 µm. Maintain the medium selected at the start, lubricated or not, for the complete service life of the gripper.

The pneumatic circuit must be pressurized progressively, to avoid uncontrolled movements.

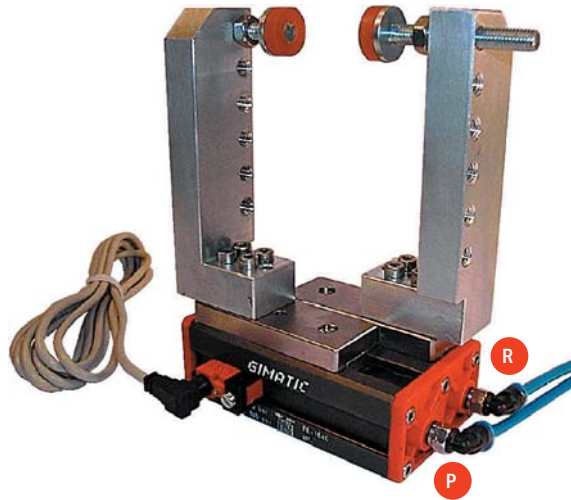

Circuito pneumatico

Possibili inconvenienti sul circuito di alimentazione dell'aria compressa:

- 1- Oscillazioni di pressione.
- 2- Riempimento pinza vuota all'avvio.
- 3- Improvvisa mancanza di pressione.
- 4- Velocità di azionamento eccessiva.

Accorgimenti per risolvere i problemi:

- 1- Serbatoio esterno (A).
- 2- Valvola di avviamento progressivo (B).
- 3- Valvole di sicurezza (C).
- 4- Regolatori di flusso (D).

Pneumatic circuit

Possible problems on a compressed air circuit:

- 1- Pressure variation.
- 2- Pressurizing with empty cylinders.
- 3- Sudden pressure black-out.
- 4- Excessive speed of the jaws.

Possible solutions:

- 1- Compressed air storage (A).
- 2- Start-up valve (B).
- 3- Safety valve (C).
- 4- Flow controller (D).

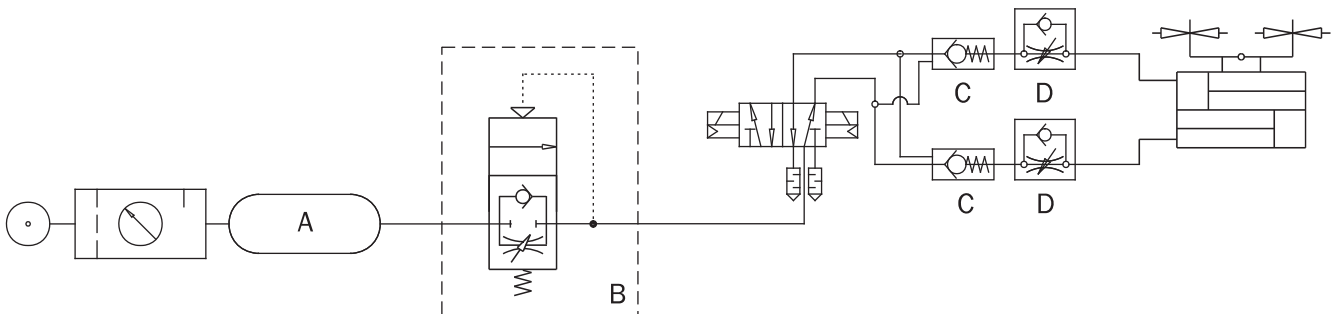

Manutenzione

La pinza va ingrassata ogni 10 milioni di cicli con:

- Molykote DX (parti metalliche).
- Molykote PG75 (guarnizioni).

Il gioco delle griffe è indicato qui sotto.

Maintenance

Grease the gripper after 10 million cycles with:

- Molykote DX (metal on metal).
- Molykote PG75 (gaskets).

The figure below shows the jaw backlash.

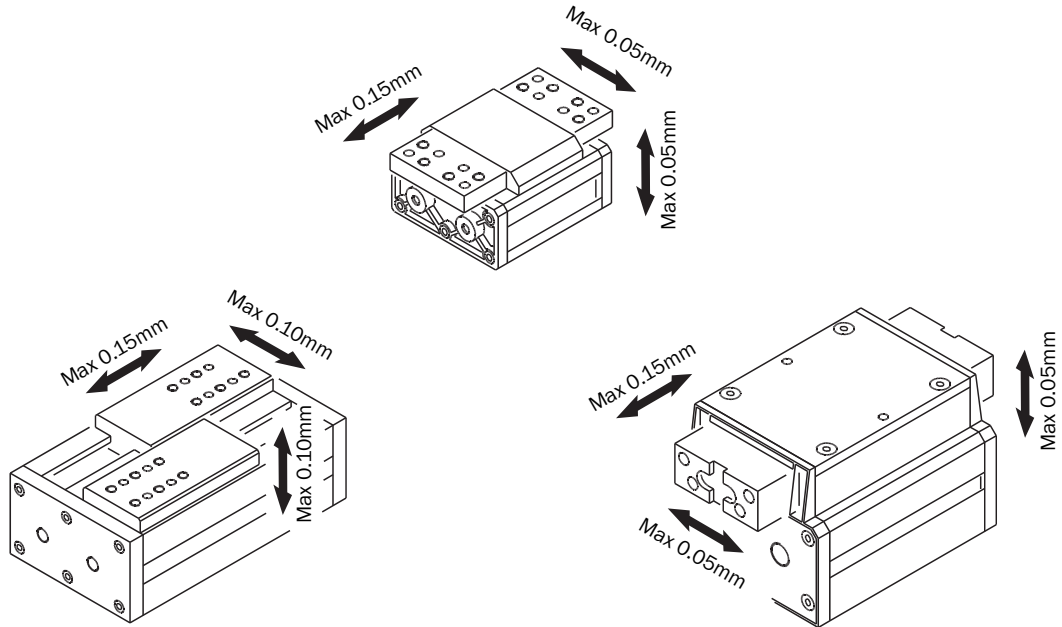

Avvertenze

Evitare il contatto con sostanze corrosive, spruzzi di saldatura, polveri abrasive, che potrebbero danneggiare la funzionalità della pinza.

Per nessun motivo, persone od oggetti estranei devono entrare nel raggio d'azione della pinza.

La pinza non deve essere messa in servizio prima che la macchina di cui fa parte sia stata dichiarata conforme alle disposizioni di sicurezza vigenti.

Caution

Avoid the gripper coming into contact with the following media: coolants which cause corrosion, grinding dust or glowing sparks. Make sure that nobody can place his/her hand between the gripping tools and there are no objects in the path of the gripper. The gripper must not run before the whole machine, on which it is mounted, complies with the laws or safety norms of your country.

