

Pinze ad espansione per interni serie MFD/MFU

- Nuovo concetto di pinza brevettato.
- Movimento verso il basso (MFD), o verso l'alto (MFU).
- La parte elastica può essere in Silicone o EPDM.
- Diametro di presa da 8 a 85 mm.
- Coni di centraggio opzionali.
- Sensori magnetici opzionali.
- Vari accessori disponibili per il fissaggio.

ID expansion grippers series MFD/MFU

- New patented concept for Air Hands.
- Downward movement (MFD), or Upward movement (MFU).
- The elastic part can be in Silicone or EPDM.
- Grip diameters from 8 to 85 mm.
- Optional nose cones for centering.
- Optional proximity magnetic sensors.
- Several mounting accessories.



MF L

Direzione del movimento

Actuation direction

- D - Verso il basso
- D - Downward
- U - Verso l'alto
- U - Upward

Diametro nominale

Base diameter

- 08 - 10 - 12 - 14 - 18 - 22
- 27 - 33 - 41 - 51 - 63

Foro passante

I modelli ...HL sono dotati di un foro passante, che si può usare per immettere aria compressa o in depressione, allo scopo di raffreddare delle parti o di controllarne la tenuta.

Through hole

The ...HL models have a central through hole. It can be used to blow compressed air, or to provide vacuum, with the purpose to cool a part, or to check the leakage.

Alimentazione

Air feeding

- C - Con raccordo coassiale
- C - By coaxial air fitting
- H - Con raccordo laterale e foro passante
- H - By side air fitting and through hole

Parte elastica

Elastic part

- S01 - in Silicone rosso
in red Silicone
- E02 - in EPDM nero
in black EPDM

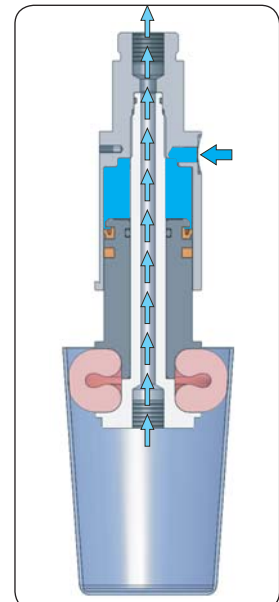

Silicone o EPDM?

La parte elastica può essere in Silicone rosso o EPDM nero. Il Silicone può essere usato su un campo di temperature più ampio e garantisce una maggiore durata, ma non è adatto in alcuni settori merceologici, perchè rende difficoltosa la verniciatura o il rivestimento delle parti che tocca. Invece l'EPDM non lascia impronte e assicura anche un maggior coefficiente di attrito. La parte elastica in Silicone o EPDM è fornita come ricambio e può essere sostituita, quando usurata. La vita media della parte elastica in EPDM è di circa 0.5 milioni di cicli. La vita media della parte elastica in Silicone è di circa 1 milione di cicli.

Silicone or EPDM?

The elastic part can be in red Silicone, or black EPDM. Silicone provides a wider temperature range and it assures a longer life time, but it is not suitable in some industries, because it makes difficult to paint or to coat the handled parts. EPDM is Non-Marking and it provides a higher friction too. The elastic part in Silicone or EPDM is available as a spare part and it can be replaced, when worn. The expected medium life time of the elastic part in EPDM is about 0.5 million cycles. The expected medium life time of the elastic part in Silicone is about 1 million cycles.

Ricambio per la parte elastica
Spare elastic part



T	MFD / MFU										
	Ø8	Ø10	Ø12	Ø14	Ø18	Ø22	Ø27	Ø33	Ø41	Ø51	Ø63
-70°C. +200°C	IF08S01	IF10S01	IF12S01U	IF14S01U	IF18S01	IF22S01	IF27S01	IF33S01	IF41S01	IF51S01	IF63S01
Prezzo Price											
-50°C. +140°C	IF08E02	IF10E02	IF12E02U	IF14E02U	IF18E02	IF22E02	IF27E02	IF33E02	IF41E02	IF51E02	IF63E02
Prezzo Price											

T - Temperatura d'esercizio
T - Operating temperature

Coni di centraggio

Sono disponibili come accessori dei coni di centraggio in nylon, con la vite inox. Per le taglie maggiori di 33, sono anche dotati del foro passante.

Centering cones

Centering cones in nylon with the stainless screw, are available as an option. For the sizes larger than 33, they are also provided with a through hole.



	MFC10	MFC12	MFC14	MFC18	MFC22	MFC27	MFC33	MFC41	MFC51	MFC63
Peso Weight	0.5 g	1 g	1 g	1.5 g	2 g	5 g	7 g	12 g	21 g	30 g
ØAD [mm]	7.8	10	11.8	15.5	18.8	21.3	28	37	47	56
ØAE [mm]	-	-	-	-	-	-	4	4	4	4
ØAG [mm]	2.9	3.5	4.5	6.5	8	9.5	12	19	26	30
MFD MFU	Ø10	Ø12	Ø14	Ø18	Ø22	Ø27	Ø33	Ø41	Ø51	Ø63
Prezzo Price										

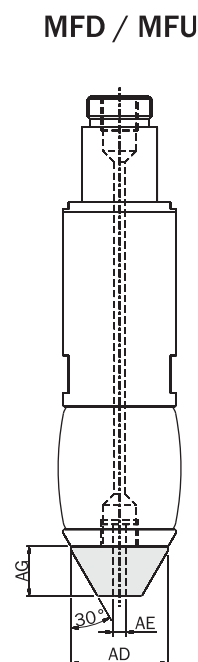

Dimensioni (mm) / Dimensions (mm)

...CL

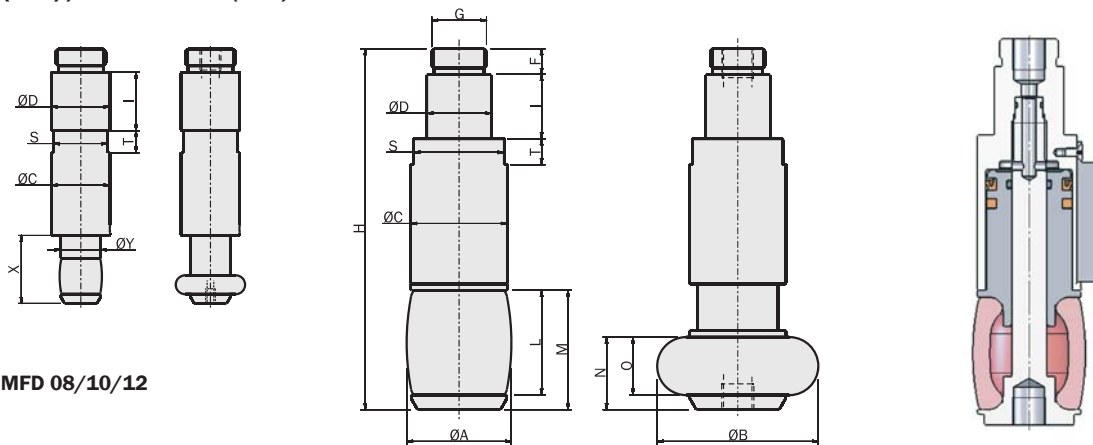

MFD 08/10/12

...HL

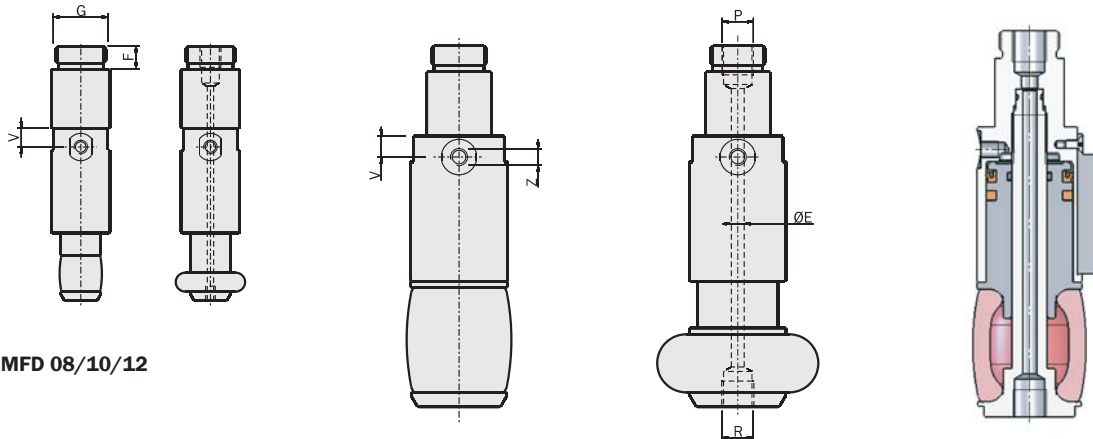

MFD 08/10/12

m - Peso
m - Weight

	m	Prezzo Price	ØA	ØB	ØC	ØD	ØE	F	G	H	I	L	M	N	O	P	R	S	T	V	Z	X	ØY	
MFD08E02CL	15g																							
MFD08S01CL	15g		8	11	14	14	-	1.5	5.5	M12x1	59.2	14	7	9.2	5.7	3.5	M5	M2	13	6	4.5	M3	14.7	7.6
MFD08E02HL	15g																							
MFD08S01HL	15g																							
MFD10E02CL	16g																							
MFD10S01CL	16g		10.5	14	14	14	-	1.5	5.5	M12x1	60.7	14	8.5	10.7	6.7	4.5	M5	M2	13	6	4.5	M3	16.2	9.5
MFD10E02HL	16g																							
MFD10S01HL	16g																							
MFD12E02CL	17g																							
MFD12S01CL	17g		13	17	14	14	-	2	5.5	M12x1	62	14	10.5	13	7.5	5	M5	M3	13	6	4.5	M3	16.8	11.8
MFD12E02HL	17g																							
MFD12S01HL	17g																							
MFD14E02CL	17g																							
MFD14S01CL	17g		15	19.5	14	14	-	2	5.5	M12x1	62.3	14	13	15.8	8.8	6	M5	M3	13	6	4.5	M3	-	-
MFD14E02HL	17g																							
MFD14S01HL	17g																							
MFD18E02CL	28g																							
MFD18S01CL	28g		19.5	25	18	14	-	2.5	5.5	M12x1	70.5	14	16.5	19.5	12	9	M5	M3	16	6	5.3	M5	-	-
MFD18E02HL	28g																							
MFD18S01HL	28g																							
MFD22E02CL	43g																							
MFD22S01CL	43g		24	31.5	21.5	14	-	2.5	5.5	M12x1	80	14	21	24.2	12.2	11	M5	M3	19	7	5.5	M5	-	-
MFD22E02HL	43g																							
MFD22S01HL	43g																							
MFD27E02CL	79g																							
MFD27S01CL	79g		28	37	25	20	-	3	8	M17x1	98	20	26	30	18	14	G1/8	M5	22	8	7	M5	-	-
MFD27E02HL	79g																							
MFD27S01HL	79g																							
MFD33E02CL	118g																							
MFD33S01CL	118g		34	45	30	20	-	4	8	M17x1	112	20	32.5	37	22.5	18	G1/8	G1/8	28	8	6.5	M5	-	-
MFD33E02HL	118g																							
MFD33S01HL	118g																							
MFD41E02CL	280g																							
MFD41S01CL	280g		42	54	40	30	-	4.3	11	M27x1	142.5	30	39.5	45	29.5	24	G1/8	G1/8	36	11	7.5	M5	-	-
MFD41E02HL	280g																							
MFD41S01HL	280g																							
MFD51E02CL	490g																							
MFD51S01CL	490g		54	68	50	30	-	5.5	11	M27x1	168	30	48	55	37	30	G1/8	G1/8	45	13	10.5	G1/8	-	-
MFD51E02HL	490g																							
MFD51S01HL	490g																							
MFD63E02CL	800g																							
MFD63S01CL	800g		66	85	60	30	-	6	11	M27x1	198	30	61	70	45	36	G1/8	G1/8	54	16	14	G1/8	-	-
MFD63E02HL	800g																							
MFD63S01HL	800g																							

Dimensioni (mm) / Dimensions (mm)

...CL

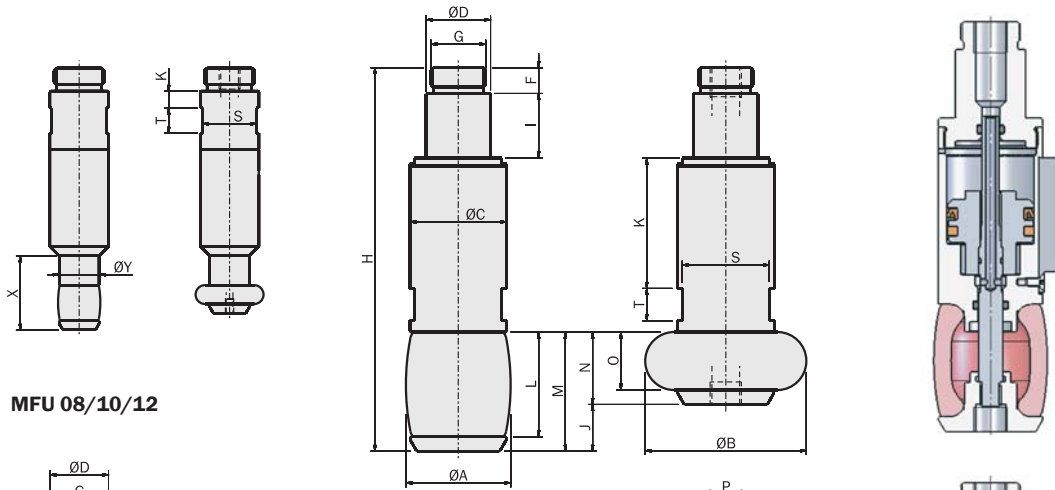

MFU 08/10/12

...HL

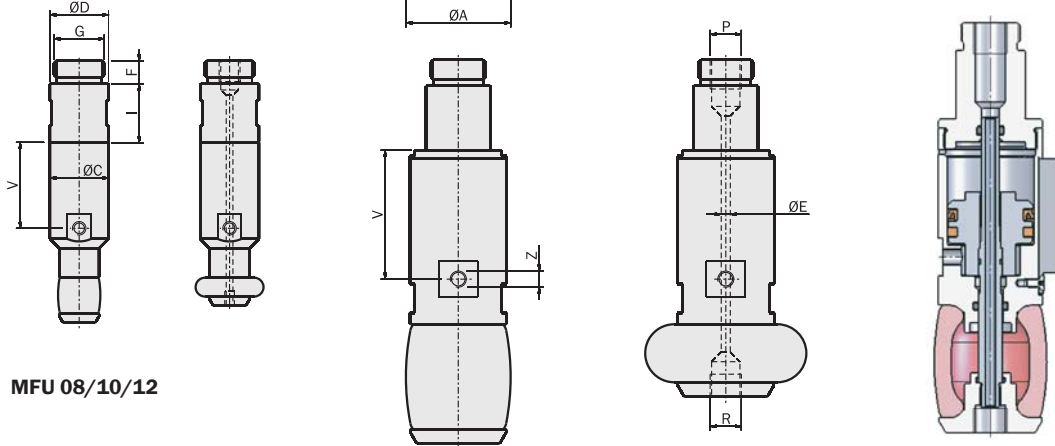

MFU 08/10/12

m - Peso
m - Weight

	m	Prezzo Price	ØA	ØB	ØC	ØD	ØE	F	G	H	I	J	K	L	M	N	O	P	R	S	T	V	Z	X	ØY
MFU08E02CL	16g																								
MFU08S01CL	16g		8	11	14	14	-	5.5	M12x1	61.5	14	3.5	4	7	9.2	5.7	3.5	M5	M2	13	6	-	-	16.3	7.6
MFU08E02HL	16g																								
MFU08S01HL	16g																								
MFU10E02CL	17g																								
MFU10S01CL	17g		10.5	14	14	14	-	5.5	M12x1	62.5	14	4	4	8.5	10.7	6.7	4.5	M5	M2	13	6	-	-	17.7	9.5
MFU10E02HL	17g																								
MFU10S01HL	17g																								
MFU12E02CL	18g																								
MFU12S01CL	18g		13	17	14	14	-	5.5	M12x1	65	14	5.5	4	10.5	13	7.5	5	M5	M3	13	6	-	-	20	11.8
MFU12E02HL	18g																								
MFU12S01HL	18g																								
MFU14E02CL	20g																								
MFU14S01CL	20g		15	19.5	14	14	-	5.5	M12x1	68.5	14	7	24.2	13	15.8	8.8	6	M5	M3	13	6	-	-	-	-
MFU14E02HL	20g																								
MFU14S01HL	20g																								
MFU18E02CL	35g																								
MFU18S01CL	35g		19.5	25	18	14	-	5.5	M12x1	78	14	7.5	29	16.5	19.5	12	9	M5	M3	16	7	-	-	-	-
MFU18E02HL	35g																								
MFU18S01HL	35g																								
MFU22E02CL	50g																								
MFU22S01CL	50g		24	31.5	21.5	14	-	5.5	M12x1	86.5	14	10	31.8	21	24.2	14.2	11	M5	M3	20	8	-	-	-	-
MFU22E02HL	50g																								
MFU22S01HL	50g																								
MFU27E02CL	100g																								
MFU27S01CL	100g		28	37	25	20	-	8	M17x1	108	20	12	37.5	26	30	18	14	G1/8	M5	22	9	-	-	-	-
MFU27E02HL	100g																								
MFU27S01HL	100g																								
MFU33E02CL	130g																								
MFU33S01CL	130g		34	45	30	20	-	8	M17x1	119	20	14.5	40.5	32.5	37	22.5	18	G1/8	G1/8	28	10	-	-	-	-
MFU33E02HL	130g																								
MFU33S01HL	130g																								
MFU41E02CL	300g																								
MFU41S01CL	300g		42	54	40	30	-	11	M27x1	147	30	15.5	45	39.5	45	29.5	24	G1/8	G1/8	36	12	-	-	-	-
MFU41E02HL	300g																								
MFU41S01HL	300g																								
MFU51E02CL	500g																								
MFU51S01CL	500g		54	68	50	30	-	11	M27x1	169	30	18	54	48	55	37	30	G1/8	G1/8	45	14	-	-	-	-
MFU51E02HL	500g																								
MFU51S01HL	500g																								
MFU63E02CL	785g																								
MFU63S01CL	785g		66	85	60	30	-	11	M27x1	194	30	25	62	61	70	45	36	G1/8	G1/8	54	16	-	-	-	-
MFU63E02HL	785g																								
MFU63S01HL	785g																								

Sensori

Nelle taglie più grandi un magnete è integrato nel pistone.
E' disponibile un accessorio per montare i sensori della serie SN.
Possono essere fissati uno o due sensori per pinza.

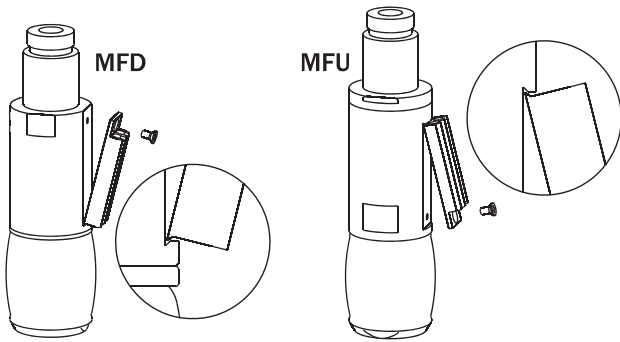

Sensors

In the larger sizes a magnet is integrated in the piston.
An optional housing for the sensors of the SN series is available.
One or two sensors can be fitted on a gripper.

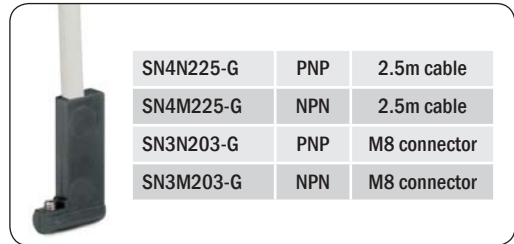

	MFD27-K	MFD33-K	MFD41-K	MFD51-K	MFD63-K
Peso Weight	4 g	5 g	5 g	6 g	7 g
AD [mm]	34	41.5	52	65	85.5
BD [mm]	28	34.5	40.5	49	54.5
CD [mm]	17	19.7	23.8	28.5	33.5
MFD	Ø27	Ø33	Ø41	Ø51	Ø63
Prezzo Price					

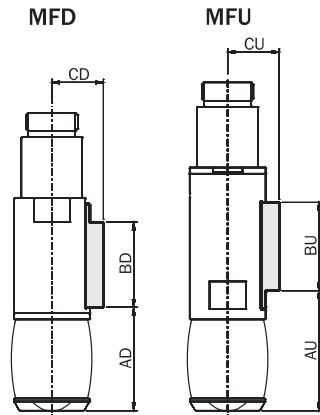

	MFU27-K	MFU33-K	MFU41-K	MFU51-K	MFU63-K
Peso Weight	4 g	5 g	5 g	6 g	7 g
AU [mm]	39.5	46.5	55.5	71.5	87.5
BU [mm]	29	33	36.5	39	45
CU [mm]	17	19.8	23.8	28.5	33.5
MFU	Ø27	Ø33	Ø41	Ø51	Ø63
Prezzo Price					



Esempi di applicazione / Application examples

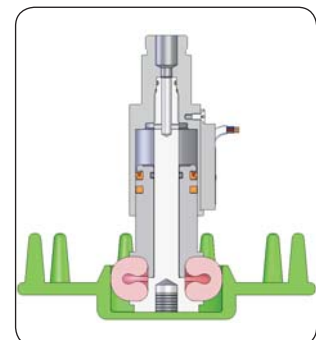
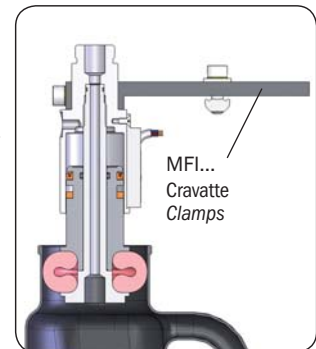
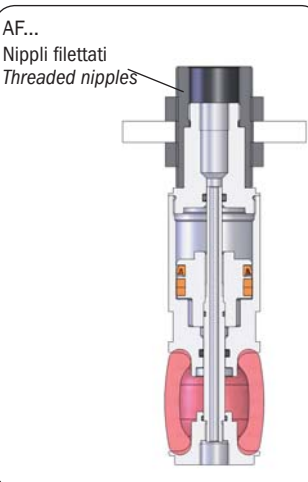
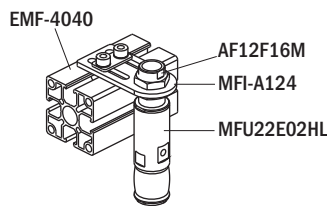
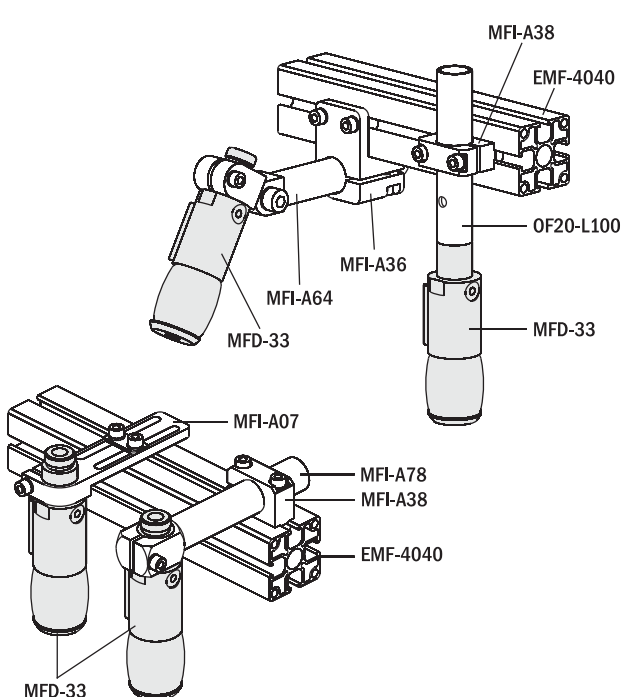

Micro pinze ad espansione per interni serie IF

- Nuovo concetto di pinza brevettato.
- Movimento verso l'alto.
- La parte elastica può essere in Silicone o NBR.
- Diametro di presa da 4.5 a 8.7 mm.

ID expansion micro grippers series IF

- New patented concept for Air Hands.
- Upward movement.
- The elastic part can be in Silicone or NBR.
- Grip diameters from 4.5 to 8.7 mm.

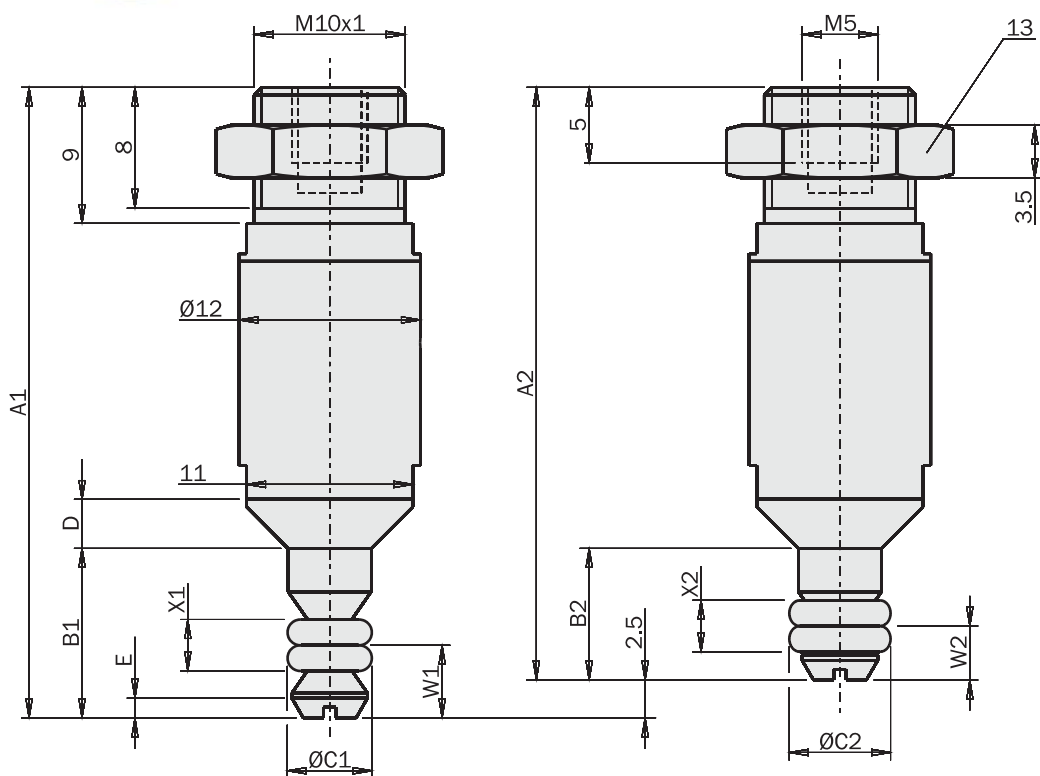

	Prezzo Price	Peso Weight	A1	A2	B1	B2	C1	C2	X1	X2	W1	W2	D	E
IFU04S01RT IFU04N03RT		7g	40.9	38.4	9.9	7.4	Ø4.5	Ø5.4	3	2.7	4	2.7	3.75x45°	1x60°
IFU05S01RT IFU05N03RT		7g	41.7	39.2	11.2	8.7	Ø5.6	Ø6.7	3.4	3.4	4.8	3.6	3.25x45°	1.3x60°
IFU06S01RT IFU06N03RT		8g	42	39.5	11.5	9	Ø6.6	Ø7.6	3.4	3.4	5.1	3.8	2.75x45°	1.4x60°
IFU07S01RT IFU07N03RT		9g	42	39.5	11.5	9	Ø7.6	Ø8.7	3.4	3.4	5.1	3.9	2.4x45°	1.5x60°

