

Pinza pneumatica ad azione basculante autocentrante a 2 griffe (serie GW)

- Azionamento a doppio effetto.
- Grande durata e affidabilità senza manutenzione.
- Diverse possibilità di fissaggio.
- Sensori magnetici opzionali.
- Disponibile anche con molla in chiusura (-NC) o in apertura (-NO).

2-jaw self centering rocking pneumatic gripper (series GW)

- Double acting.
- Long life and reliability, maintenance free.
- Various options for fastening.
- Optional proximity magnetic sensors.
- Spring closed (-NC) or spring open (-NO) option.



	GW-10	GW-16	GW-20	GW-25
Fluido Medium	Aria compressa filtrata, lubrificata / non lubrificata Filtered, lubricated / non lubricated compressed air			
Pressione di esercizio Operating pressure range	2 ÷ 8 bar			
Temperatura di esercizio Operating temperature range	5° ÷ 60°C.			
Coppia di serraggio per griffa in apertura a 6 bar Opening torque at 6 bar on each jaw	11 Ncm	45 Ncm	89 Ncm	178 Ncm
Coppia di serraggio totale in apertura a 6 bar Opening total torque at 6 bar	22 Ncm	90 Ncm	178 Ncm	356 Ncm
Coppia di serraggio per griffa in chiusura a 6 bar Closing torque at 6 bar on each jaw	8 Ncm	36 Ncm	78 Ncm	160 Ncm
Coppia di serraggio totale in chiusura a 6 bar Closing total torque at 6 bar	16 Ncm	72 Ncm	156 Ncm	320 Ncm
Corsa (±1°) Stroke	2x20°	2x20°	2x20°	2x20°
Frequenza max funzionamento continuativo Maximum working frequency	3 Hz	3 Hz	2 Hz	2 Hz
Consumo d'aria per ciclo Cycle air consumption	0.7 cm ³	3 cm ³	6 cm ³	11 cm ³
Tempo di chiusura senza carico Closing time without load	0.005 s	0.005 s	0.02 s	0.02 s
Ripetibilità Repetition accuracy	0.04°	0.04°	0.04°	0.04°
Peso Weight	39 g	88 g	171 g	300 g

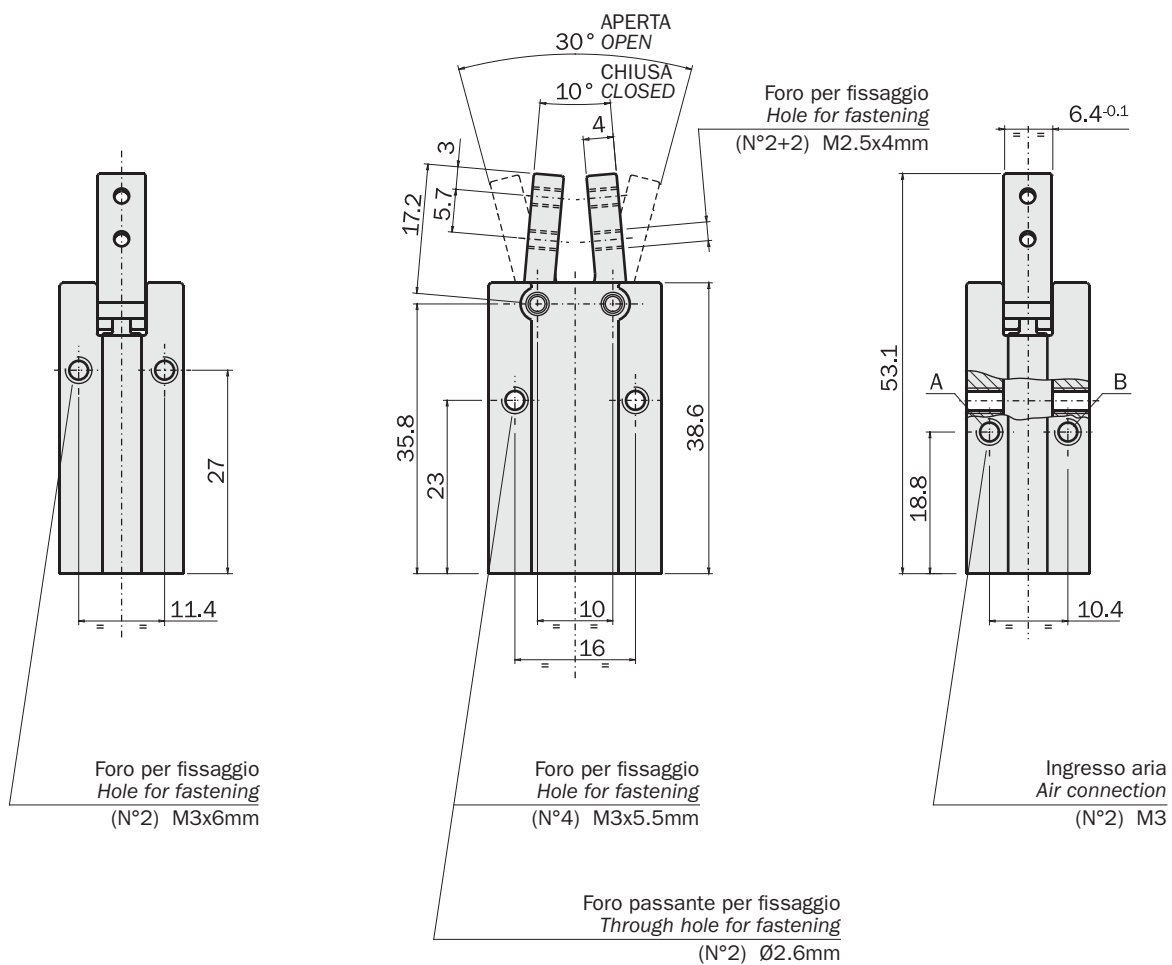
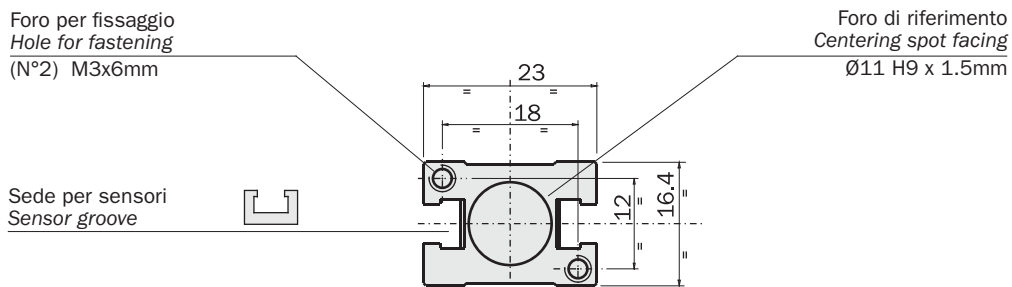

Aria compressa in A: apertura della pinza.
Aria compressa in B: chiusura della pinza.
Compressed air in A: gripper opening.
Compressed air in B: gripper closing.



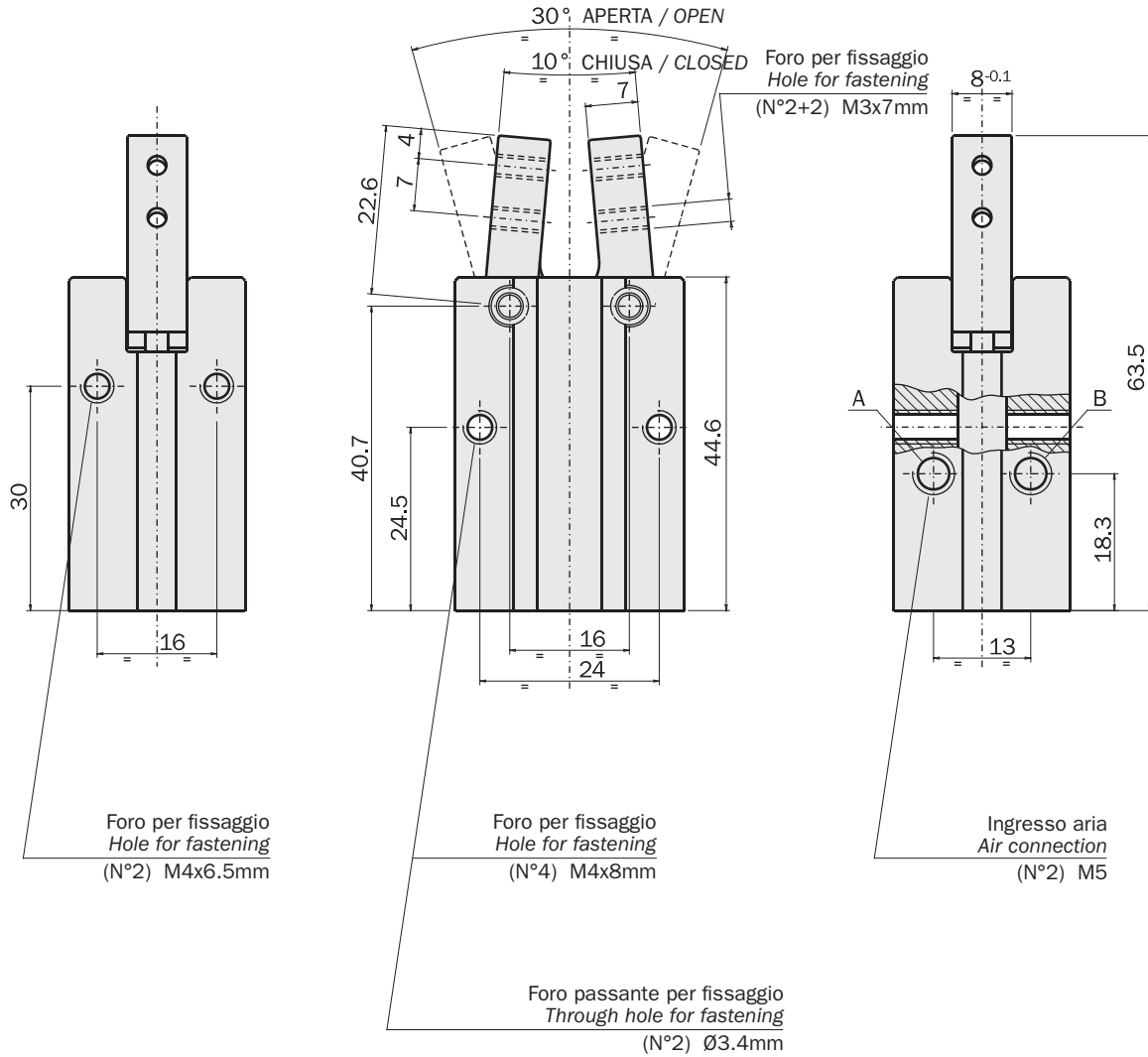
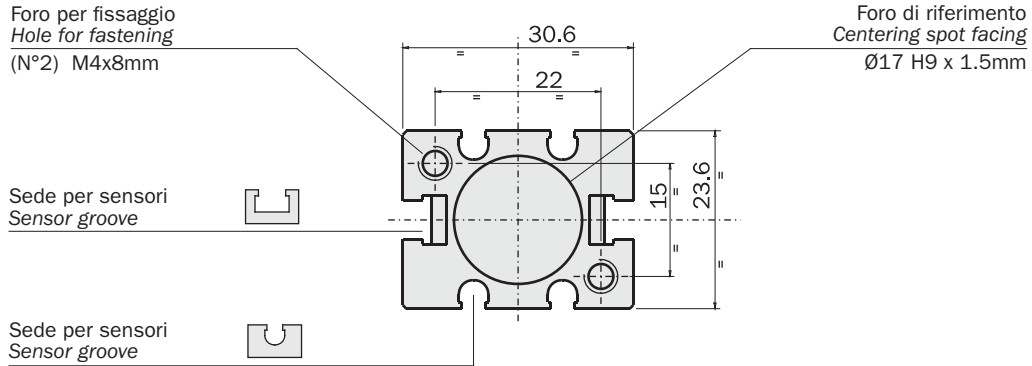

Aria compressa in A: apertura della pinza.
Aria compressa in B: chiusura della pinza.
Compressed air in A: gripper opening.
Compressed air in B: gripper closing.



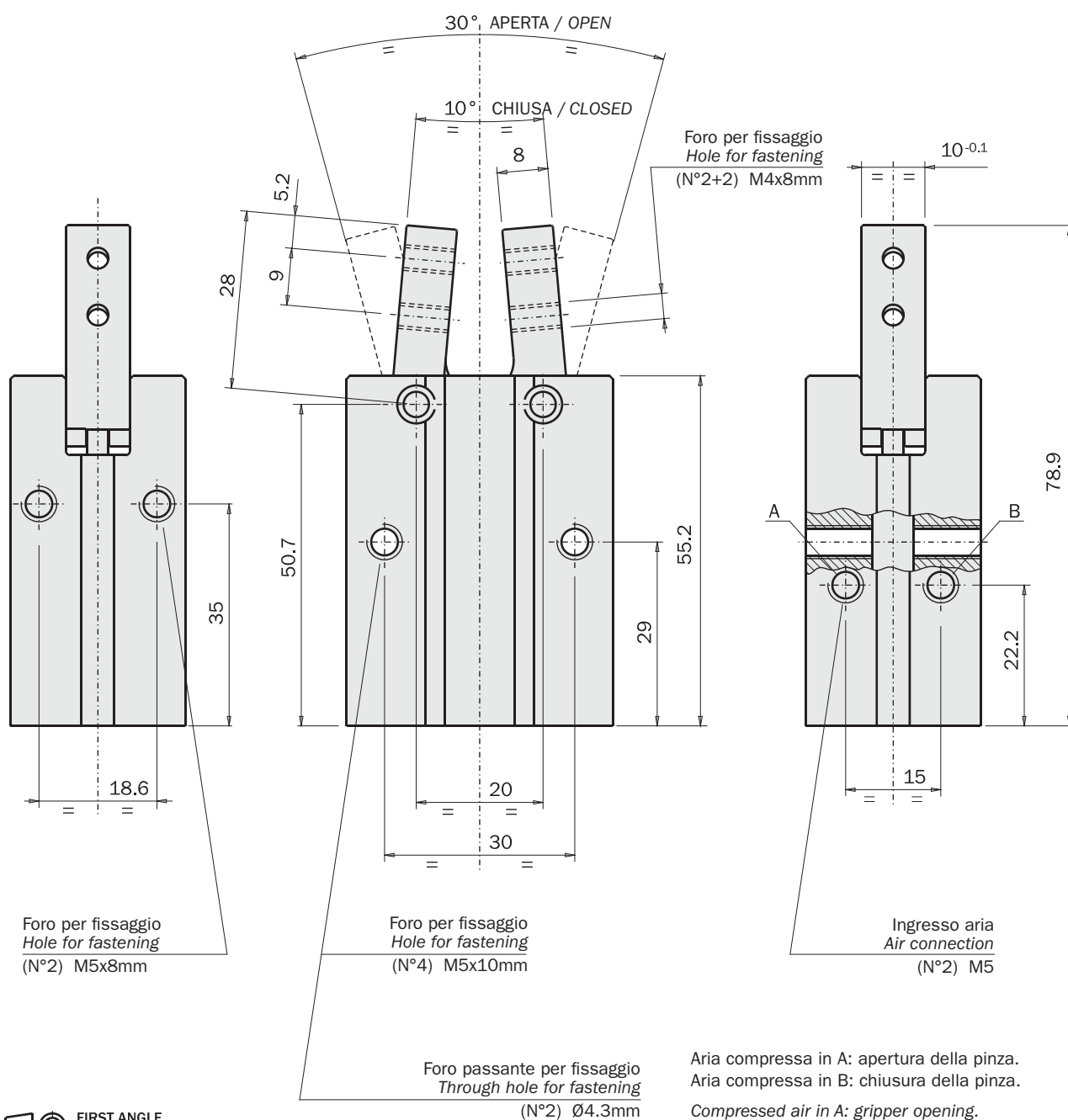
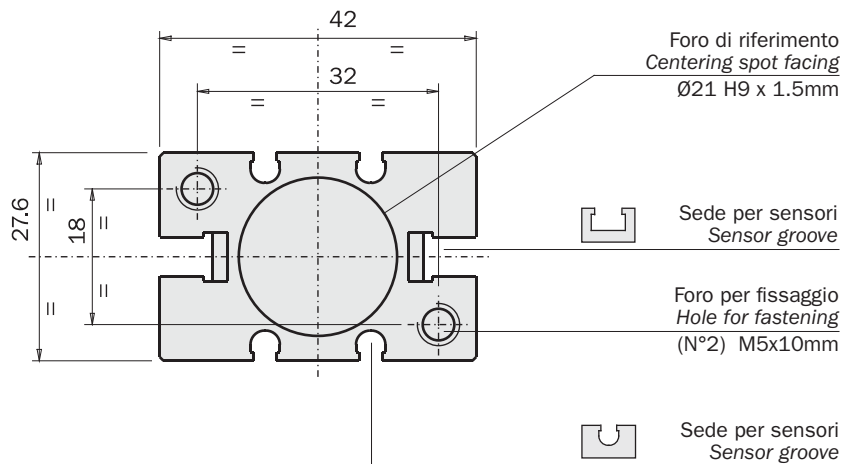

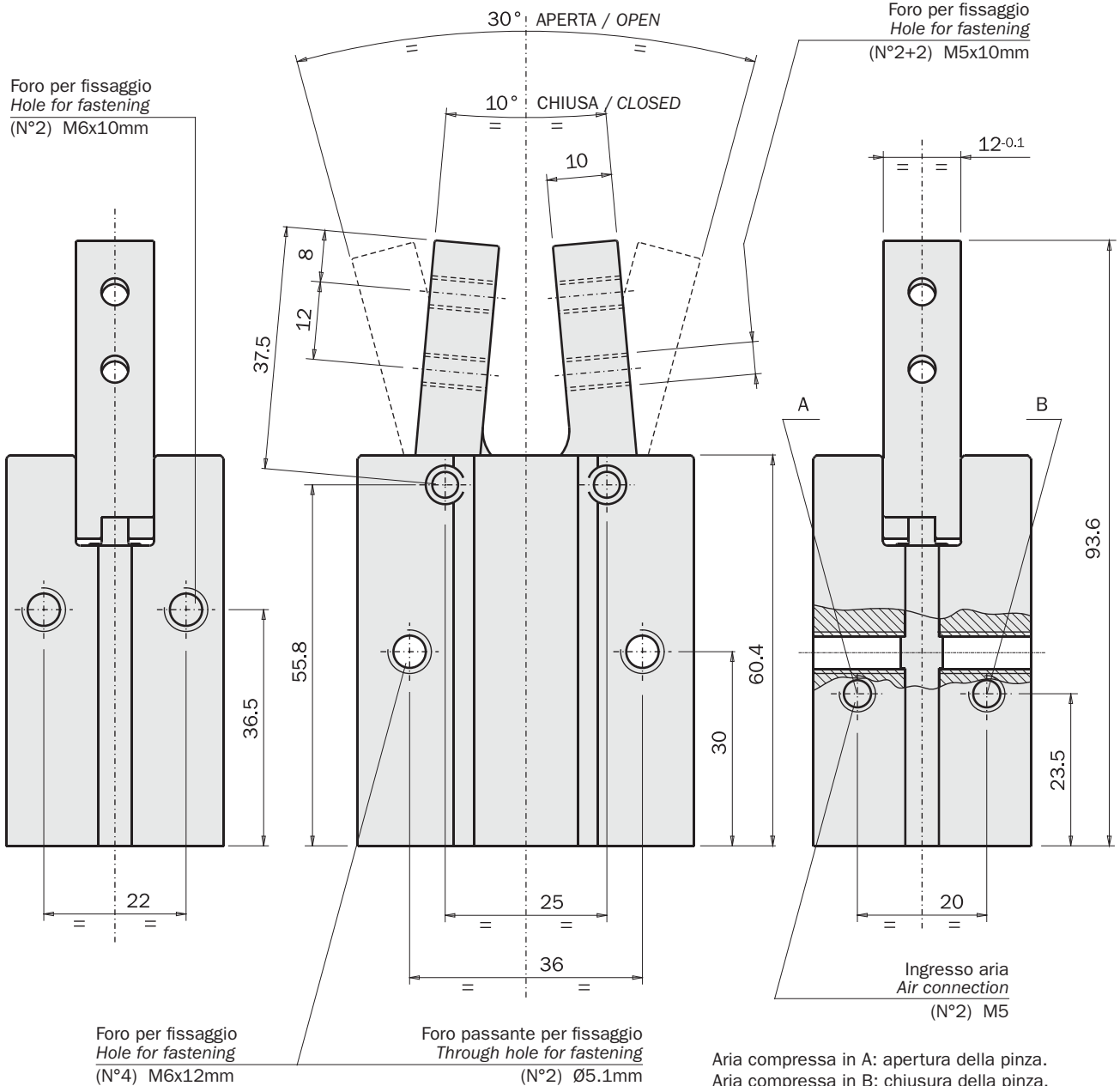
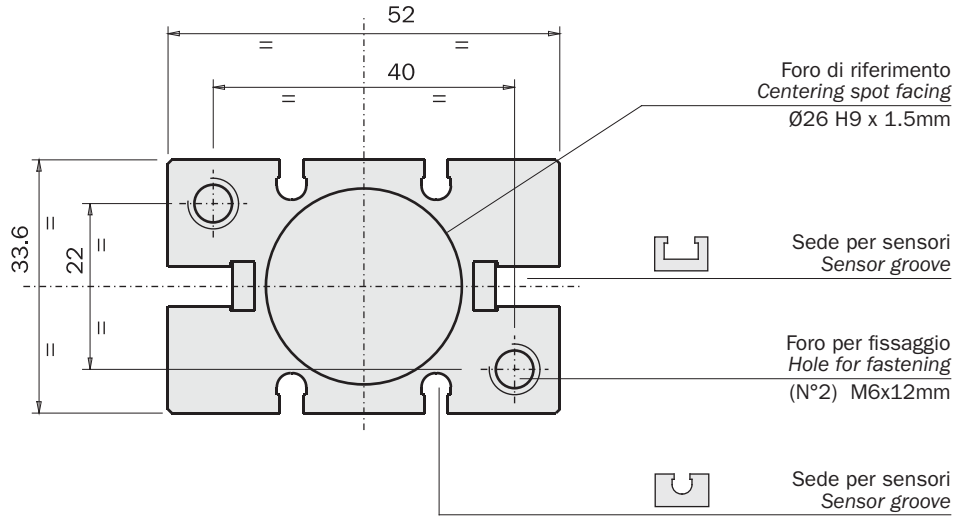

Serraggio

La pinza è a doppio effetto e può quindi essere usata per serrare il carico sia dall'esterno (B) che dall'interno (A). La forza di serraggio è maggiore in apertura.

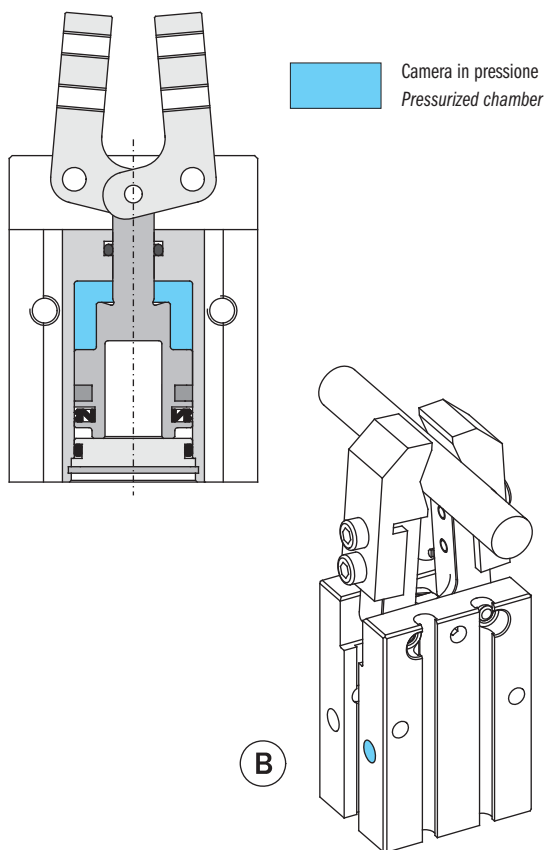

Gripping

The gripper is double-acting for either internal (A) or external (B) gripping applications. The opening force is higher.

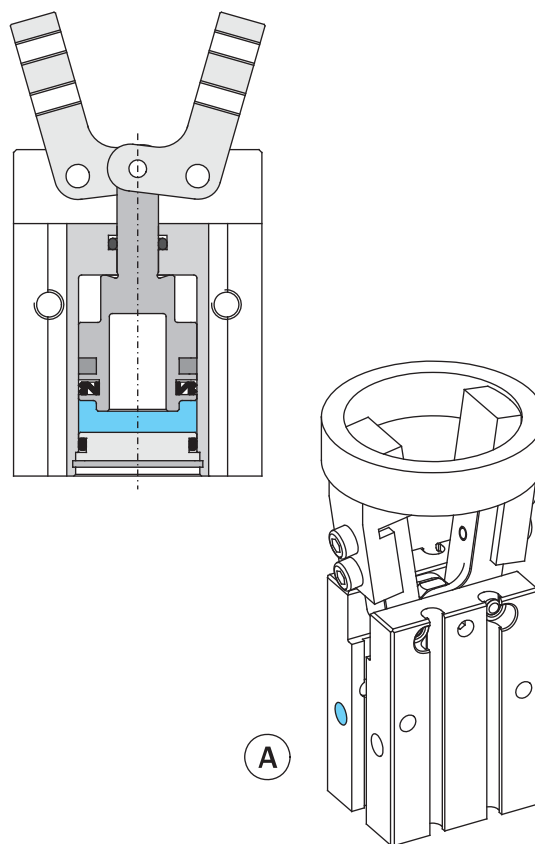

A richiesta è disponibile la versione con la molla in chiusura (-NC) o in apertura (-NO), che in assenza d'aria garantisce circa un quarto della forza disponibile a 6 bar.

It is also available, on request, with a closing (-NC) or opening (-NO) spring, providing, after a pressure black-out, about one fourth of the output force at 6 bar.

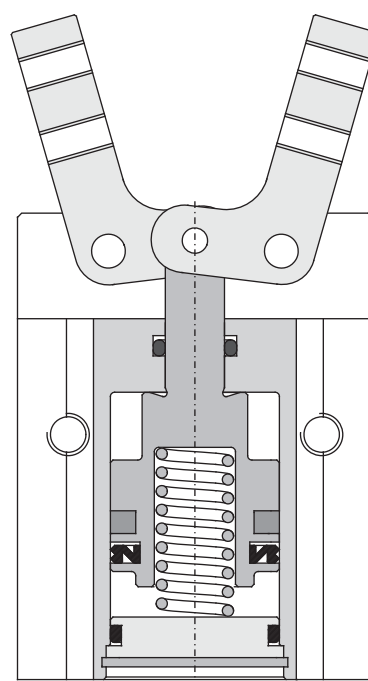
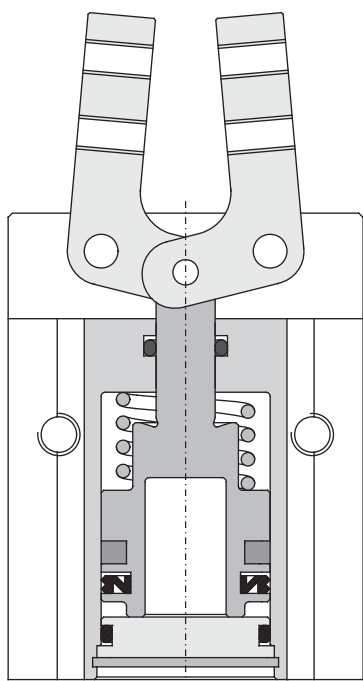

Fissaggio

La pinza può essere montata in posizione fissa oppure su parti in movimento: in questo caso va considerata la forza d'inerzia cui la pinza ed il suo carico sono sottoposti.

1 - Per fissare la pinza sul lato più largo utilizzare due viti passanti nella piastra ed avvitate nel foro filettato (A) della pinza.

2 - Il fissaggio sul lato largo è possibile anche utilizzando due viti (B) passanti attraverso i fori (A). In questo caso l'utilizzo di sensori nelle cave rettangolari può essere impossibile.

3 - Per fissare la pinza sul lato più stretto utilizzare due viti passanti nella piastra ed avvitate nel foro filettato (E) della pinza.

4 - Per fissare la pinza sul fondo utilizzare due viti passanti nella piastra ed avvitate nel foro filettato (C) ed una pastiglia di centraggio nella lamatura centrale (D). In questo caso si deve prevedere lo spazio per i sensori (X e Y).

Fastening

The gripper can be fastened to a static or moving part. When on a moving part, you must pay attention to the forces created by inertia over the gripper and its load.

1 - To fasten the gripper on the wider side, use a plate with two through holes and two screws to be screwed on the threaded holes (A) on the gripper housing.

2 - It is possible to fasten the gripper on the wider side also with two screws (B) passing through the threaded holes (A). In this case sensors on the T-slot could be unusable.

3 - To fasten the gripper on the narrow side, two screws passing through the holes on the plate, must be screwed into the threaded holes (E) on the gripper housing.

4 - The gripper can be fastened on the bottom as well, using two screws passing through the holes on the plate and screwed into the threaded holes (C) on the gripper housing. For the reference use a centering disc in the spot face (D). In this case the necessary room for sensor must be provided (X and Y).

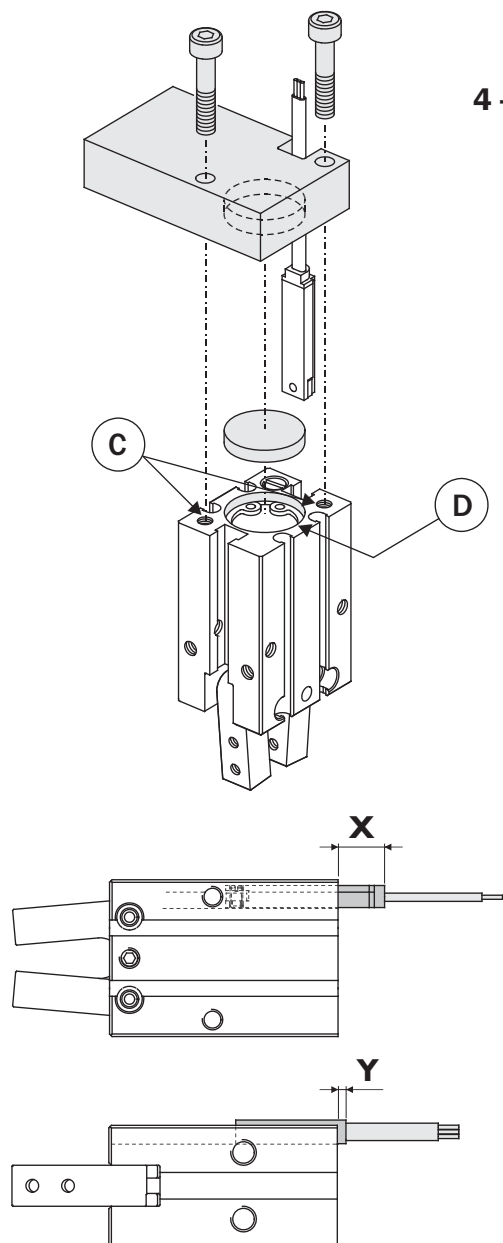
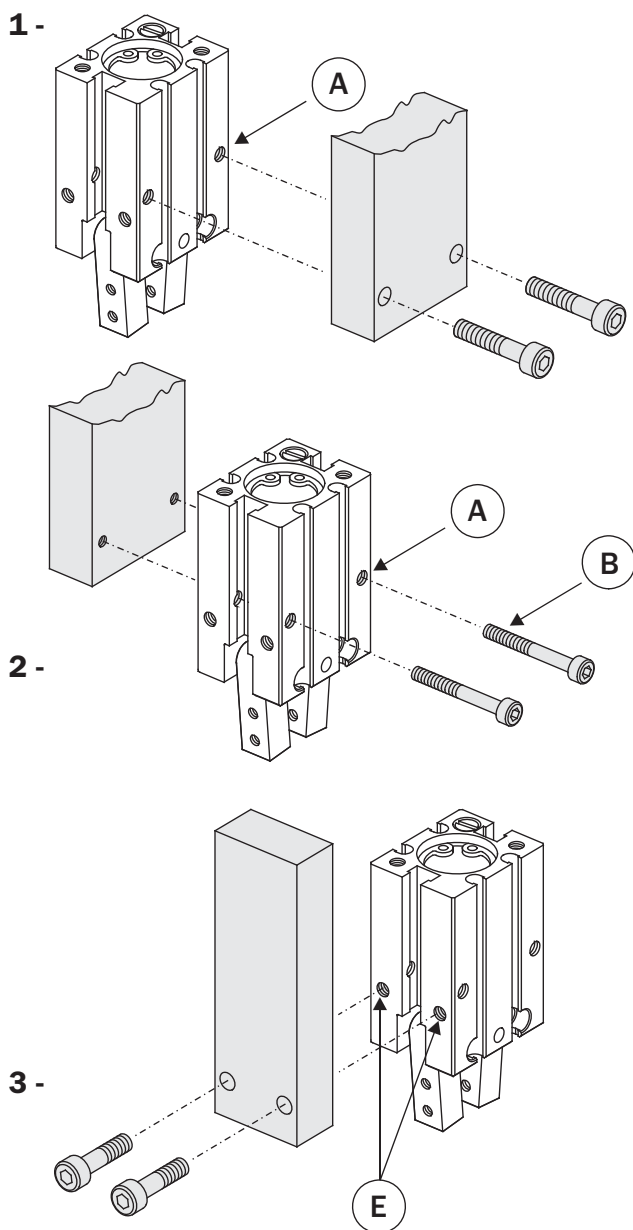

Costruire le dita di presa il più possibile corte e leggere.
Fissarle con due viti nei fori filettati (G).
Per il centraggio sulle griffe si può fare riferimento alla quota calibrata (F).

The gripping tools must be as short and light as possible.
They must be fastened by two screws in the threaded holes (G).
For a precise positioning on the jaw use the calibrated dimension (F).

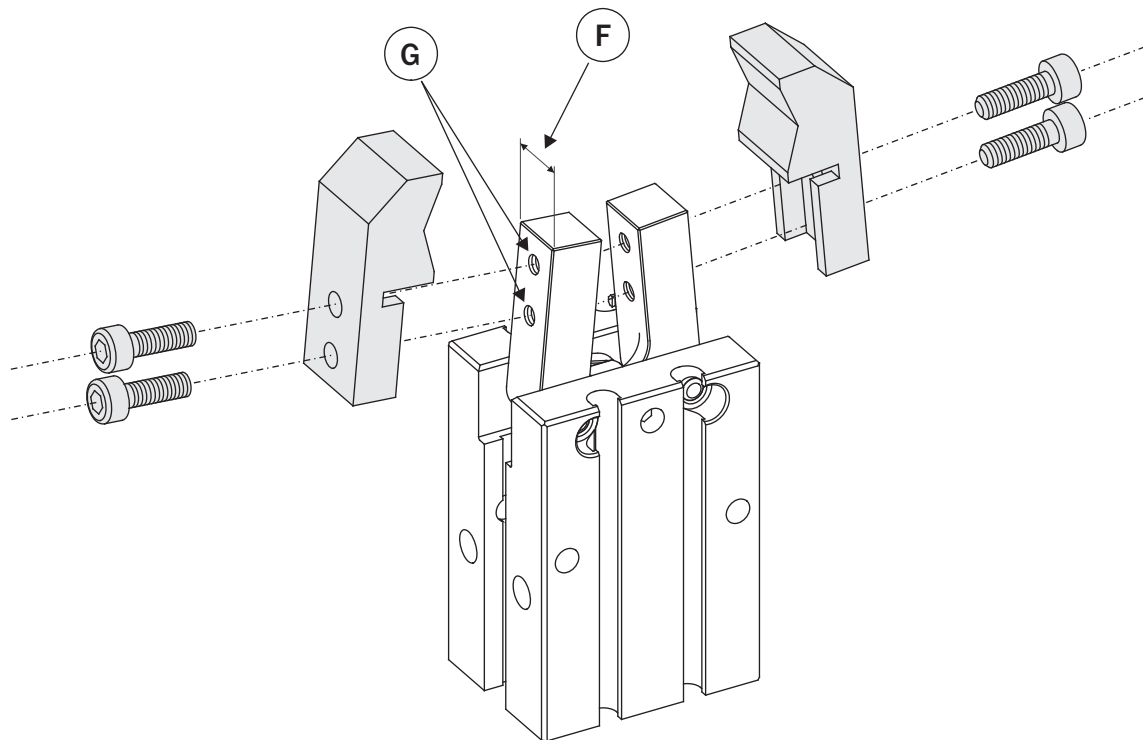

	GW-10	GW-16	GW-20	GW-25
A	M3x5.5 mm	M4x8 mm	M5x10 mm	M6x12 mm
B	M2.5x22 mm	M3x30 mm	M4x35 mm	M5x45 mm
C	M3x6 mm	M4x8 mm	M5x10 mm	M6x12 mm
D	Ø11H9 x 1.5 mm	Ø17H9 x 1.5 mm	Ø21H9 x 1.5 mm	Ø26H9 x 1.5 mm
E	M3x6 mm	M4x6.5 mm	M5x8 mm	M6x10 mm
F	6.4 ^{-0.1} mm	8 ^{-0.1} mm	10 ^{-0.1} mm	12 ^{-0.1} mm
G	M2.5x4 mm	M3x7 mm	M4x8 mm	M5x10 mm

	GW-10	GW-16	GW-20	GW-25
SC	/	X=2 mm	X=0 mm	X=0 mm
SL	X=10 mm + cable	X=10 mm + cable	X=10 mm + cable	X=10 mm + cable
SN	X=2 mm	X=Y=3 mm	X=Y=3 mm	X=Y=2 mm
SS	X=2 mm + cable	X=Y=3 mm + cable	X=Y=3 mm + cable	X=Y=2 mm + cable

Forza di serraggio

I grafici mostrano la forza per griffa espressa dalla pinza in funzione della pressione e del braccio di leva Z.

Gripping force

The graphs show the gripping force on each jaw, as a function of the operating pressure and the gripping tool length Z.

La forza indicata in questi grafici è riferita alla singola griffa. La forza totale è il doppio.

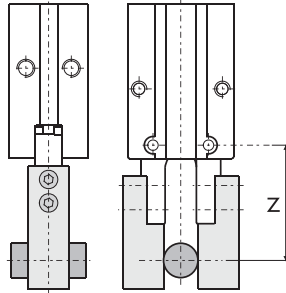

The force shown in these graphs refers to one jaw. The total force is double.

GW-10

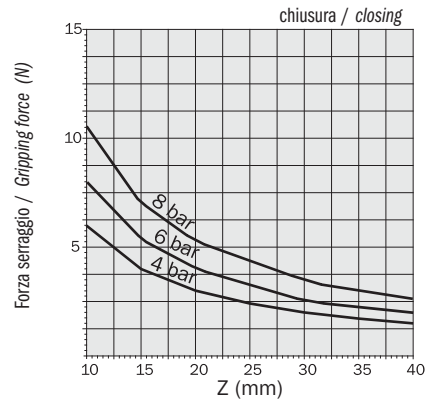
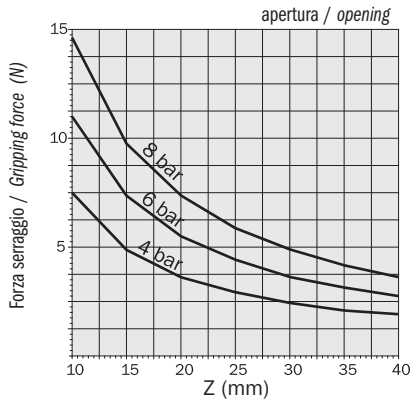

GW-16

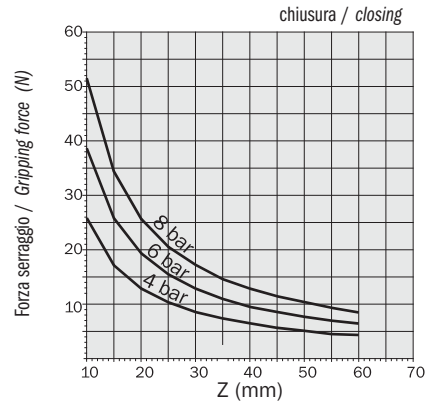
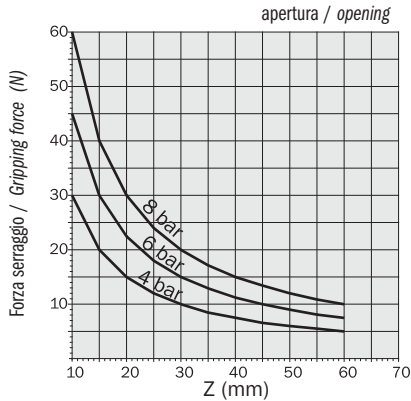

GW-20

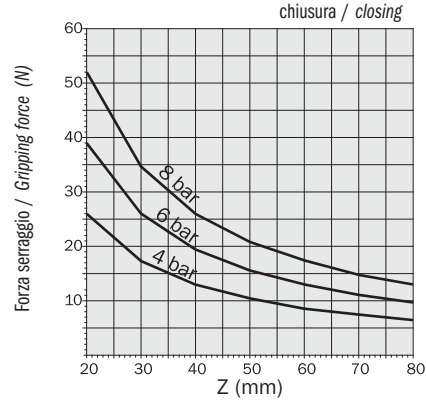
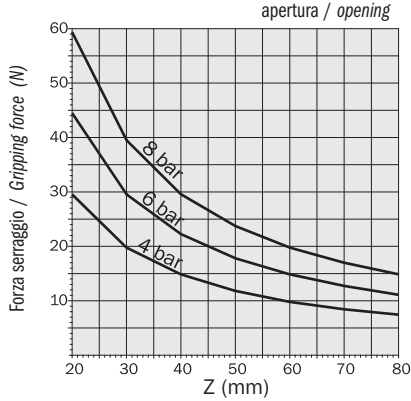

GW-25

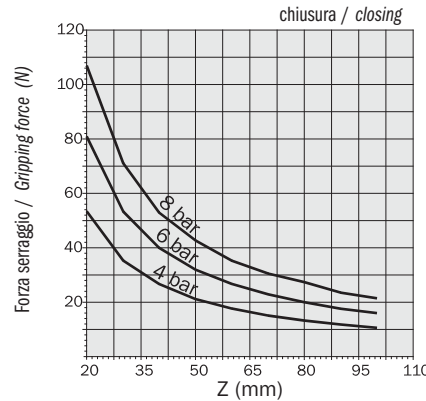
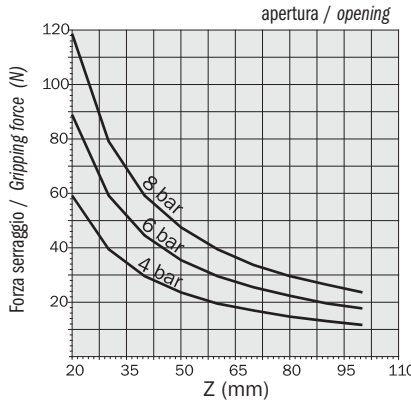

Carichi di sicurezza

Consultare la tabella per i carichi massimi ammissibili. Forze e coppie eccessive possono danneggiare la pinza e causare difficoltà di funzionamento compromettendo la sicurezza dell'operatore. F, Mx, My, Mz, sono i carichi massimi ammissibili in condizioni statiche, cioè con le griffe ferme.

Safety loads

Check the table for maximum permitted loads. Excessive forces or torques can damage the gripper, cause functioning troubles and endanger the safety of the operator. F, Mx, My, Mz, are maximum permitted static loads. Static means with motionless jaws.

	GW-10	GW-16	GW-20	GW-25
F	40 N	60 N	100 N	100 N
Mx	0.4 Nm	1.2 Nm	1.5 Nm	2.2 Nm
My	0.5 Nm	0.9 Nm	2.2 Nm	2.2 Nm
Mz	0.5 Nm	0.9 Nm	2.2 Nm	2.2 Nm

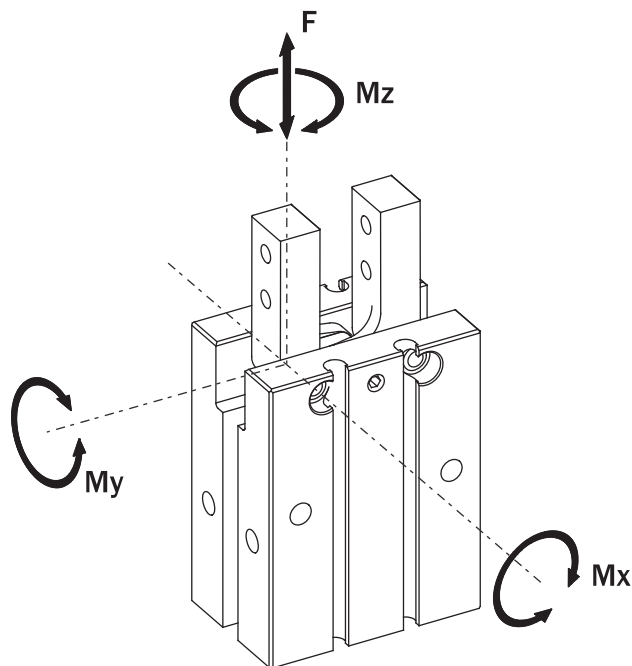

Regolazione della velocità

I grafici indicano il momento di inerzia massimo ammissibile per ogni dito di presa (J), in funzione del tempo di apertura o chiusura delle griffe (t). Usare i regolatori di flusso (non forniti) per ottenere la velocità desiderata.

Speed adjustment

The graphs show the maximum permitted moment of inertia on each gripping tool (J), as a factor of the opening or closing time (t). Use flow controllers (not supplied) to get the proper speed.

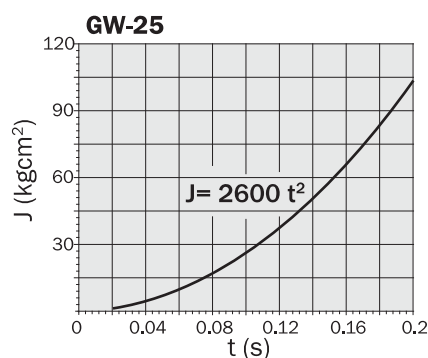
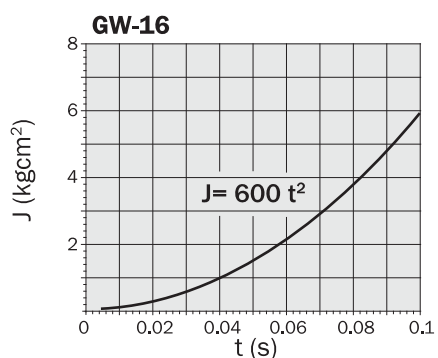
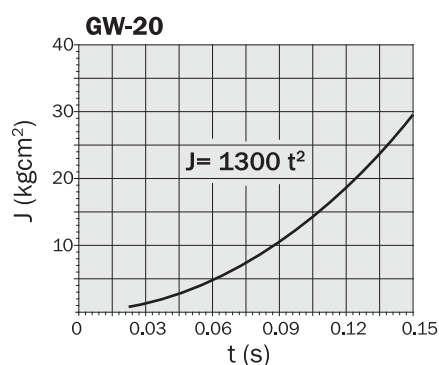
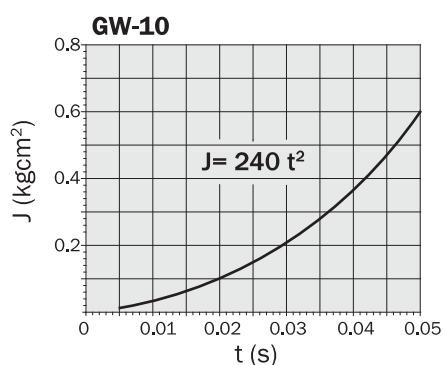

Sensori

Il rilevamento della posizione di lavoro è affidato a uno o più sensori magnetici di prossimità (opzionali), che rilevano la posizione attraverso il magnete sul pistone.

Quindi, per un corretto funzionamento, è da evitare l'impiego in presenza di forti campi magnetici od in prossimità di grosse masse di materiale ferromagnetico.

I sensori utilizzabili sono:



Sensors

The operating position can be checked by one or more magnetic sensors (optional), that detect the position by the magnet on the piston inside.

Therefore a near big mass of ferromagnetic material or intense magnetic fields may cause sensing troubles.

Use sensors:

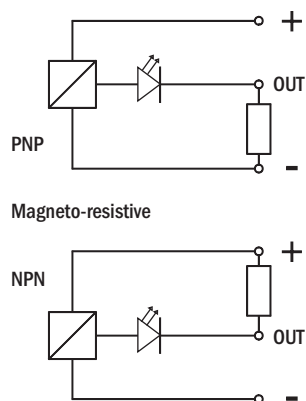

			GW-10		GW-16		GW-20		GW-25		
			U	U	U	U	U	U	U	U	
SC4N225Y	PNP	2.5m cable	<input type="checkbox"/>	<input type="checkbox"/>	<input checked="" type="checkbox"/>	<input type="checkbox"/>	<input checked="" type="checkbox"/>	<input type="checkbox"/>	<input checked="" type="checkbox"/>	<input type="checkbox"/>	<input checked="" type="checkbox"/>
SC3N203Y	PNP	M8 connector	<input type="checkbox"/>	<input type="checkbox"/>	<input checked="" type="checkbox"/>	<input type="checkbox"/>	<input checked="" type="checkbox"/>	<input type="checkbox"/>	<input checked="" type="checkbox"/>	<input type="checkbox"/>	<input checked="" type="checkbox"/>
SL4N225-G	PNP	2.5m cable	<input checked="" type="checkbox"/>	<input type="checkbox"/>	<input checked="" type="checkbox"/>	<input type="checkbox"/>	<input checked="" type="checkbox"/>	<input type="checkbox"/>	<input checked="" type="checkbox"/>	<input type="checkbox"/>	<input checked="" type="checkbox"/>
SL4M225-G	NPN	2.5m cable	<input checked="" type="checkbox"/>	<input type="checkbox"/>	<input checked="" type="checkbox"/>	<input type="checkbox"/>	<input checked="" type="checkbox"/>	<input type="checkbox"/>	<input checked="" type="checkbox"/>	<input type="checkbox"/>	<input checked="" type="checkbox"/>
SL3N203-G	PNP	M8 connector	<input checked="" type="checkbox"/>	<input type="checkbox"/>	<input checked="" type="checkbox"/>	<input type="checkbox"/>	<input checked="" type="checkbox"/>	<input type="checkbox"/>	<input checked="" type="checkbox"/>	<input type="checkbox"/>	<input checked="" type="checkbox"/>
SL3M203-G	NPN	M8 connector	<input checked="" type="checkbox"/>	<input type="checkbox"/>	<input checked="" type="checkbox"/>	<input type="checkbox"/>	<input checked="" type="checkbox"/>	<input type="checkbox"/>	<input checked="" type="checkbox"/>	<input type="checkbox"/>	<input checked="" type="checkbox"/>
SN4N225-G	PNP	2.5m cable	<input type="checkbox"/>	<input checked="" type="checkbox"/>	<input type="checkbox"/>	<input checked="" type="checkbox"/>	<input type="checkbox"/>	<input checked="" type="checkbox"/>	<input type="checkbox"/>	<input checked="" type="checkbox"/>	<input type="checkbox"/>
SN4M225-G	NPN	2.5m cable	<input type="checkbox"/>	<input checked="" type="checkbox"/>	<input type="checkbox"/>	<input checked="" type="checkbox"/>	<input type="checkbox"/>	<input checked="" type="checkbox"/>	<input type="checkbox"/>	<input checked="" type="checkbox"/>	<input type="checkbox"/>
SN3N203-G	PNP	M8 connector	<input type="checkbox"/>	<input checked="" type="checkbox"/>	<input type="checkbox"/>	<input checked="" type="checkbox"/>	<input type="checkbox"/>	<input checked="" type="checkbox"/>	<input type="checkbox"/>	<input checked="" type="checkbox"/>	<input type="checkbox"/>
SN3M203-G	NPN	M8 connector	<input type="checkbox"/>	<input checked="" type="checkbox"/>	<input type="checkbox"/>	<input checked="" type="checkbox"/>	<input type="checkbox"/>	<input checked="" type="checkbox"/>	<input type="checkbox"/>	<input checked="" type="checkbox"/>	<input type="checkbox"/>
SS4N225-G	PNP	2.5m cable	<input checked="" type="checkbox"/> (1)	<input checked="" type="checkbox"/>	<input checked="" type="checkbox"/> (1)	<input checked="" type="checkbox"/>	<input checked="" type="checkbox"/> (1)	<input checked="" type="checkbox"/>	<input checked="" type="checkbox"/> (1)	<input checked="" type="checkbox"/>	<input checked="" type="checkbox"/> (1)
SS4M225-G	NPN	2.5m cable	<input checked="" type="checkbox"/> (1)	<input checked="" type="checkbox"/>	<input checked="" type="checkbox"/> (1)	<input checked="" type="checkbox"/>	<input checked="" type="checkbox"/> (1)	<input checked="" type="checkbox"/>	<input checked="" type="checkbox"/> (1)	<input checked="" type="checkbox"/>	<input checked="" type="checkbox"/> (1)
SS3N203-G	PNP	M8 connector	<input checked="" type="checkbox"/> (1)	<input checked="" type="checkbox"/>	<input checked="" type="checkbox"/> (1)	<input checked="" type="checkbox"/>	<input checked="" type="checkbox"/> (1)	<input checked="" type="checkbox"/>	<input checked="" type="checkbox"/> (1)	<input checked="" type="checkbox"/>	<input checked="" type="checkbox"/> (1)
SS3M203-G	NPN	M8 connector	<input checked="" type="checkbox"/> (1)	<input checked="" type="checkbox"/>	<input checked="" type="checkbox"/> (1)	<input checked="" type="checkbox"/>	<input checked="" type="checkbox"/> (1)	<input checked="" type="checkbox"/>	<input checked="" type="checkbox"/> (1)	<input checked="" type="checkbox"/>	<input checked="" type="checkbox"/> (1)

(1) Utilizzando l'adattatore (SS.004.000) fornito nella confezione K-SENS.

(1) By the adapter (SS.004.000) provided with the pack K-SENS.



Connessione pneumatica

La pinza si alimenta con aria compressa dai fori laterali (A e B) montandovi i raccordi dell'aria ed i relativi tubi (non forniti).

Aria compressa in A: apertura della pinza.
Aria compressa in B: chiusura della pinza.

La pinza è azionata con aria compressa filtrata (5÷40 µm) non necessariamente lubrificata.

La scelta iniziale, lubrificata o non lubrificata, deve essere mantenuta per tutta la vita della pinza.

L'impianto pneumatico deve essere pressurizzato gradualmente, per evitare movimenti incontrollati.

Compressed air feeding

The compressed air feeding can be accomplished on the lateral air ports (A and B) with fittings and hoses (not supplied).

Compressed air in A: gripper opening.
Compressed air in B: gripper closing.

The compressed air, must be filtered from 5 to 40 µm. Maintain the medium selected at the start, lubricated or not, for the complete service life of the gripper.

The pneumatic circuit must be pressurized progressively, to avoid uncontrolled movements.

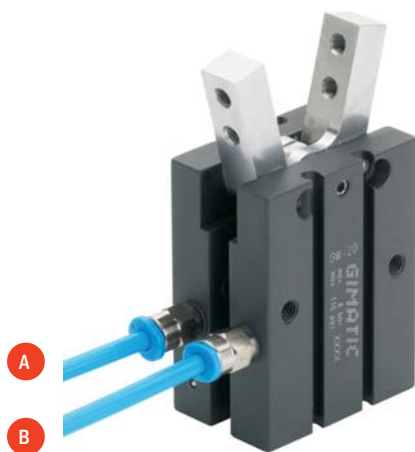

Circuito pneumatico

Possibili inconvenienti sul circuito di alimentazione dell'aria compressa:

- 1- Oscillazioni di pressione
- 2- Riempimento pinza vuota all'avvio
- 3- Improvvisa mancanza di pressione
- 4- Velocità di azionamento eccessiva

Accorgimenti per risolvere i problemi:

- 1- Serbatoio esterno (A)
- 2- Valvola di avviamento progressivo (B)
- 3- Valvole di sicurezza (C)
- 4- Regolatori di flusso (D)

Pneumatic circuit

Possible problems on a compressed air circuit:

- 1- Pressure variation
- 2- Pressurizing with empty cylinder
- 3- Sudden pressure black-out
- 4- Excessive speed of the jaws

Possible solutions:

- 1- Compressed air storage (A)
- 2- Start-up valve (B)
- 3- Safety valve (C)
- 4- Flow controller (D)

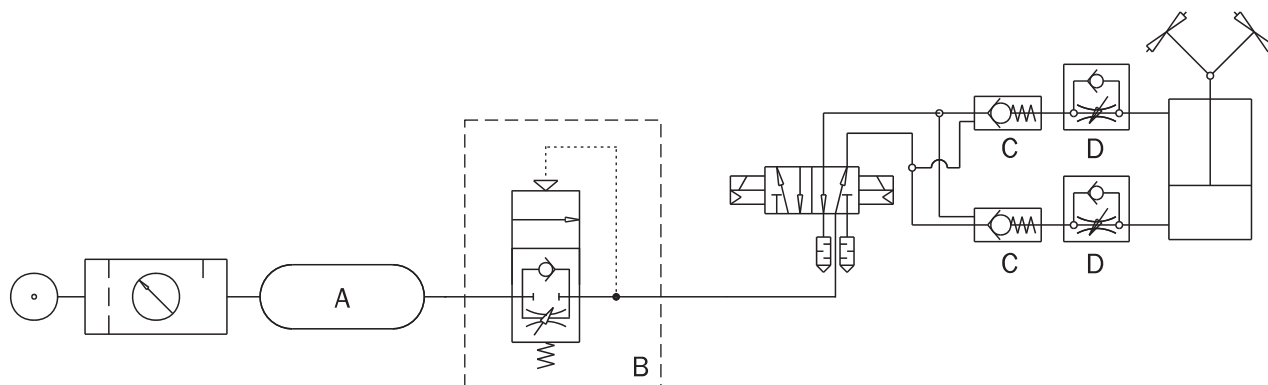

Avvertenze

Evitare il contatto con sostanze corrosive, spruzzi di saldatura, polveri abrasive, che potrebbero danneggiare la funzionalità della pinza.

Per nessun motivo, persone od oggetti estranei devono entrare nel raggio d'azione della pinza.

La pinza non deve essere messa in servizio prima che la macchina di cui fa parte sia stata dichiarata conforme alle disposizioni di sicurezza vigenti.

Caution

Avoid the gripper coming into contact with the following media: coolants which cause corrosion, grinding dust or glowing sparks. Make sure that nobody can place his/her hand between the gripping tools and there are no objects in the path of the gripper. The gripper must not run before the whole machine, on which it is mounted, complies with the laws or safety norms of your country.

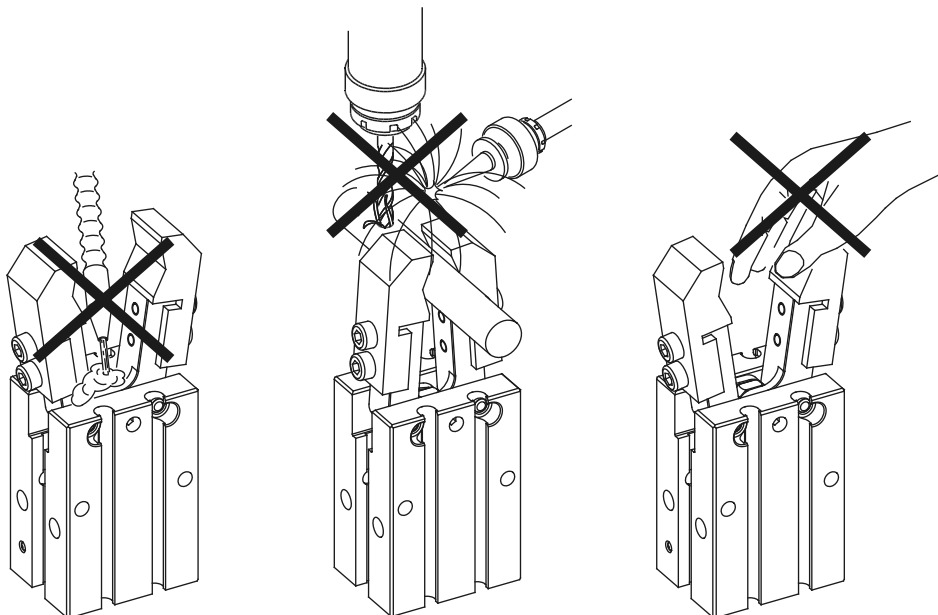
**Manutenzione**

La pinza va ingrassata ogni 10 milioni di cicli con:

- Molykote DX (parti metalliche);
- Molykote PG75 (guarnizioni).

Il gioco delle griffe è indicato qui sotto.
NON RIMUOVERE MAI I TAPPI.

Maintenance

Grease the gripper after 10 million cycles with:

- Molykote DX (metal on metal);
- Molykote PG75 (gaskets).

The figure below shows the jaw backlash.
NEVER REMOVE THE PLUGS.

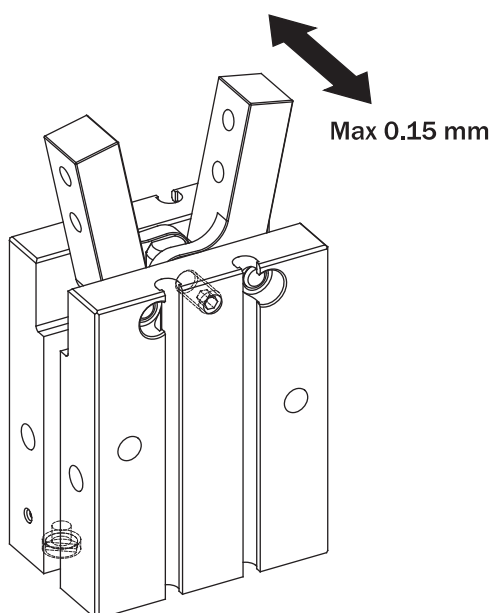

Elenco delle parti / Part list

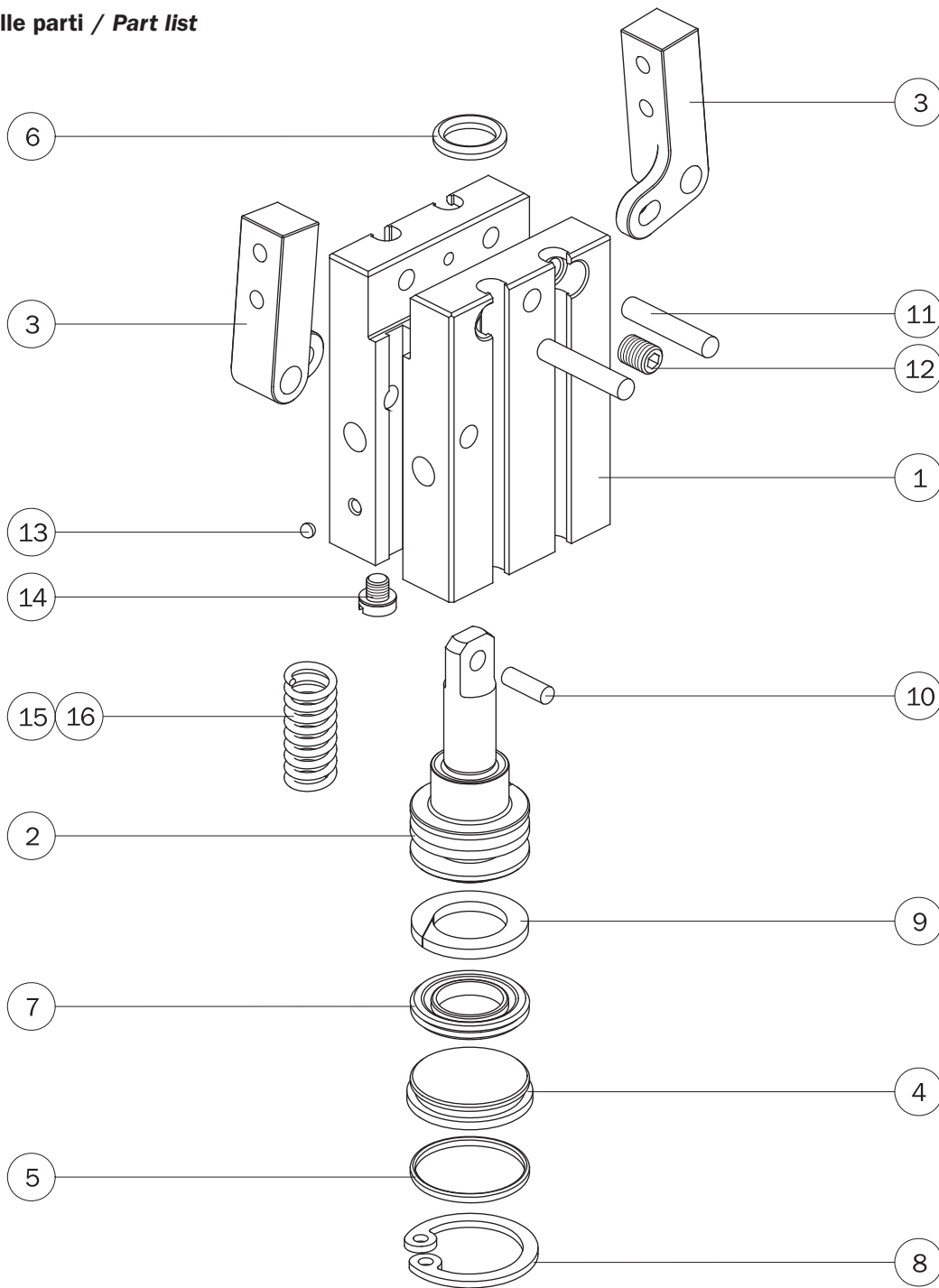

		GW-10	GW-16	GW-20	GW-25		
1	Corpo pinza	GW-10-01	GW-16-01	GW-20-01	GW-25-01	Gripper housing	1
2	Pistone	GW-10-02	GW-16-02	GW-20-02	GW-25-02	Piston	2
3	Griffa	GW-10-03	GW-16-03	GW-20-03	GW-25-03	Jaw	3
4	Tappo	GS-10-06	GS-16-06	GS-20-06	GS-25-06	Cap	4
5	O-RING	Ø1.78x6.75 (GUAR-012)	Ø1x14 (GUAR-084)	Ø1.78x17.17 (GUAR-076)	Ø1.78x21.95 (GUAR-025)	O-RING gasket	5
6	O-RING	Ø1x5 (GUAR-021)	Ø1.78x6.75 (GUAR-012)	Ø1.78x6.75 (GUAR-012)	Ø1.78x7.66 (GUAR-045)	O-RING gasket	6
7	Guarnizione dinamica	10x5x2.4 (GUAR-106E)	16x9x2.5 (GUAR-002P)	20x13x2.5 (GUAR-040P)	25x18x2.4 (GUAR-003M)	Dynamic gasket	7
8	Anello elastico per int.	Ø11 mm DIN 472	Ø17 mm DIN 472	Ø21 mm DIN 472	Ø26 mm DIN 472	Retaining ring	8
9	Magnete	GS-10-11	PAR-16-10B	PAR-20-10B	PAR-25-10B	Magnet	9
10	Spina di riferimento	Ø2x6.3 mm DIN 5402	Ø2.5x7.8 mm DIN 5402	Ø3x10 mm DIN 6325	Ø4x12 mm DIN 6325	Dowel pin	10
11	Spina di riferimento	Ø2.5x15.8 mm DIN 5402	Ø3x16 mm DIN 6325	Ø4x20 mm DIN 6325	Ø4x21.8 mm DIN 5402	Dowel pin	11
12	Vite senza testa	M3x4 mm INOX DIN913	M4x5 mm INOX DIN913	M4x8 mm INOX DIN913	M5x10 mm INOX DIN913	Grub screw	12
13	Sfera	Ø2 mm AA DIN 5401A	Ø2 mm AA DIN 5401A	Ø2 mm AA DIN 5401A	Ø2 mm AA DIN 5401A	Ball	13
14	Tappo M3	-	DT-205	DT-205	DT-205	Plug	14
15	Molla (solo per NC)	GS-10-08	GW-16-08	GS-20-08	PAR-25-11B	Spring (only NC)	15
16	Molla (solo per NO)	GS-10-09	PAR-16-12B	PAR-20-12B	GS-25-09	Spring (only NO)	16