

GRIPPER WITH THE FINGERS

PREHENSEUR POUR LE VIDE

GREIFERFINGERN

PRENSOR PARA VACIO

Max pressure 2 bar, Max temperature +40°C

POSIZIONE CHIUSA
CLOSED POSITION
POSITION FERMEE
GESCHLOSSENE POSITION
CERRADA POSICION

POSIZIONE APERTA
OPEN POSITION
POSITION OUVERTE
GEÖFFNETE POSITION
ABERTA POSICION

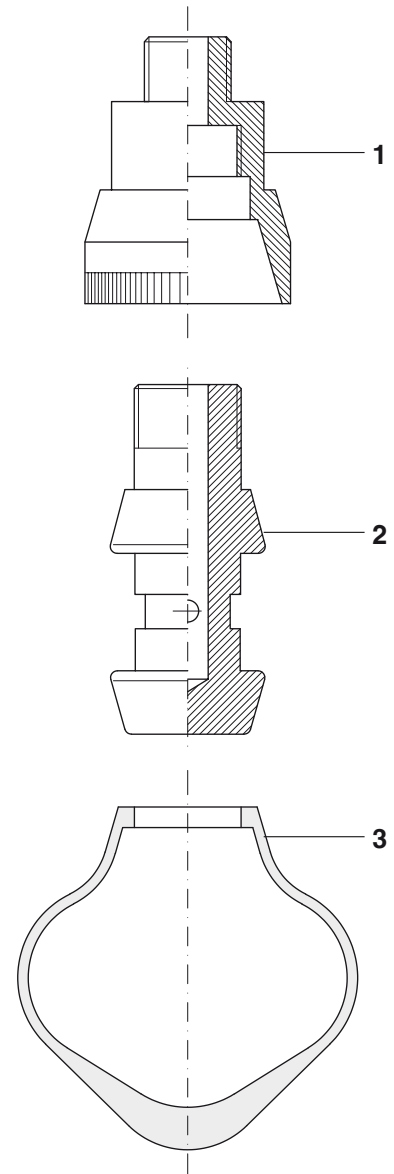
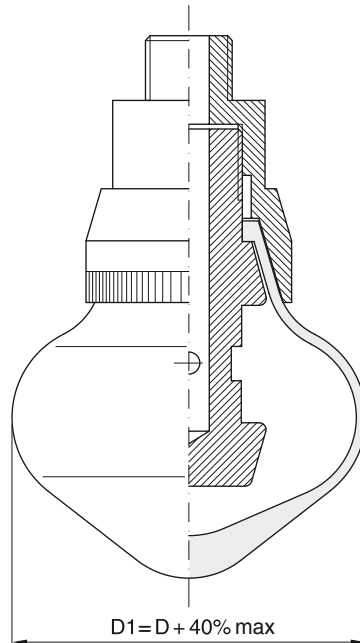
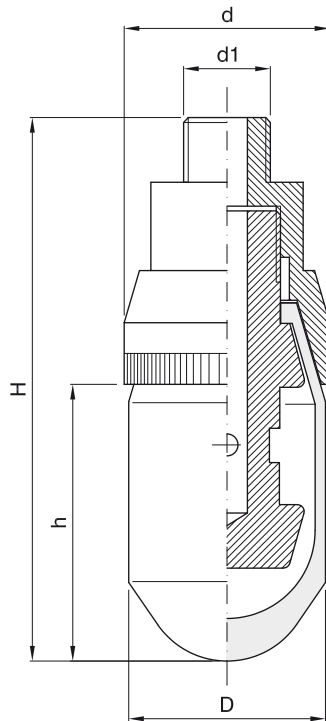

COD.	D	D1= D + 40% max	d	d 1	H	h
051.0009	17	25	18.5	M 10	102	51
051.0005	20	28	18.5	M 10	101	50
051.0008	27	40	27	M 12	119	63
051.0007	37	50	39	M 16	120	60
051.0006	47	65	49	M 20	124	61

COD.		COD.	MATERIALE	MATERIAL	MATERIEL	WERKSTOFF	MATERIAL
051.0006	1	030.0016	PA	PA	PA	PA	PA
	2	030.0017	PA	PA	PA	PA	PA
	3	040.0112	GOMMA	RUBBER	CAOUTCHOUC	GUMMI	GOMA
051.0007	1	030.0014	PA	PA	PA	PA	PA
	2	030.0015	PA	PA	PA	PA	PA
	3	040.0113	GOMMA	RUBBER	CAOUTCHOUC	GUMMI	GOMA
051.0008	1	030.0012	PA	PA	PA	PA	PA
	2	030.0013	PA	PA	PA	PA	PA
	3	040.0111	GOMMA	RUBBER	CAOUTCHOUC	GUMMI	GOMA
051.0005	1	030.0026	AL	AL	AL	AL	AL
	2	030.0027	AL	AL	AL	AL	AL
	3	040.0156	GOMMA	RUBBER	CAOUTCHOUC	GUMMI	GOMA
051.0009	1	030.0026	AL	AL	AL	AL	AL
	2	030.0027	AL	AL	AL	AL	AL
	3	040.0126	GOMMA	RUBBER	CAOUTCHOUC	GUMMI	GOMA